

1 LX 470 ELECTRICAL WIRING DIAGRAM

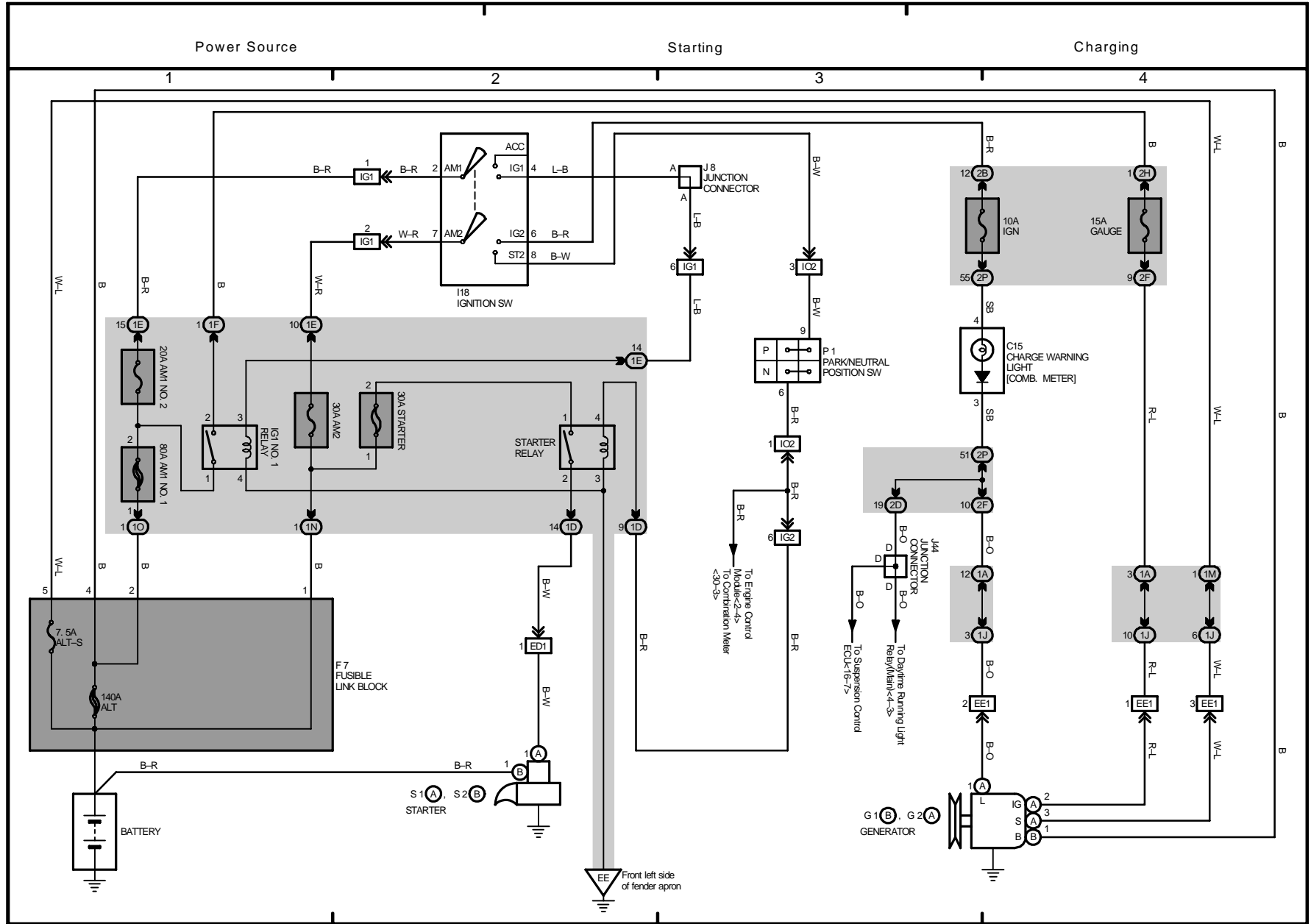

2001 LEXUS LX 470 (EMD427U)

# M OVERALL ELECTRICAL WIRING DIAGRAM

2 LX 470

(Cont. next page)

## Engine Control and Engine Immobiliser System

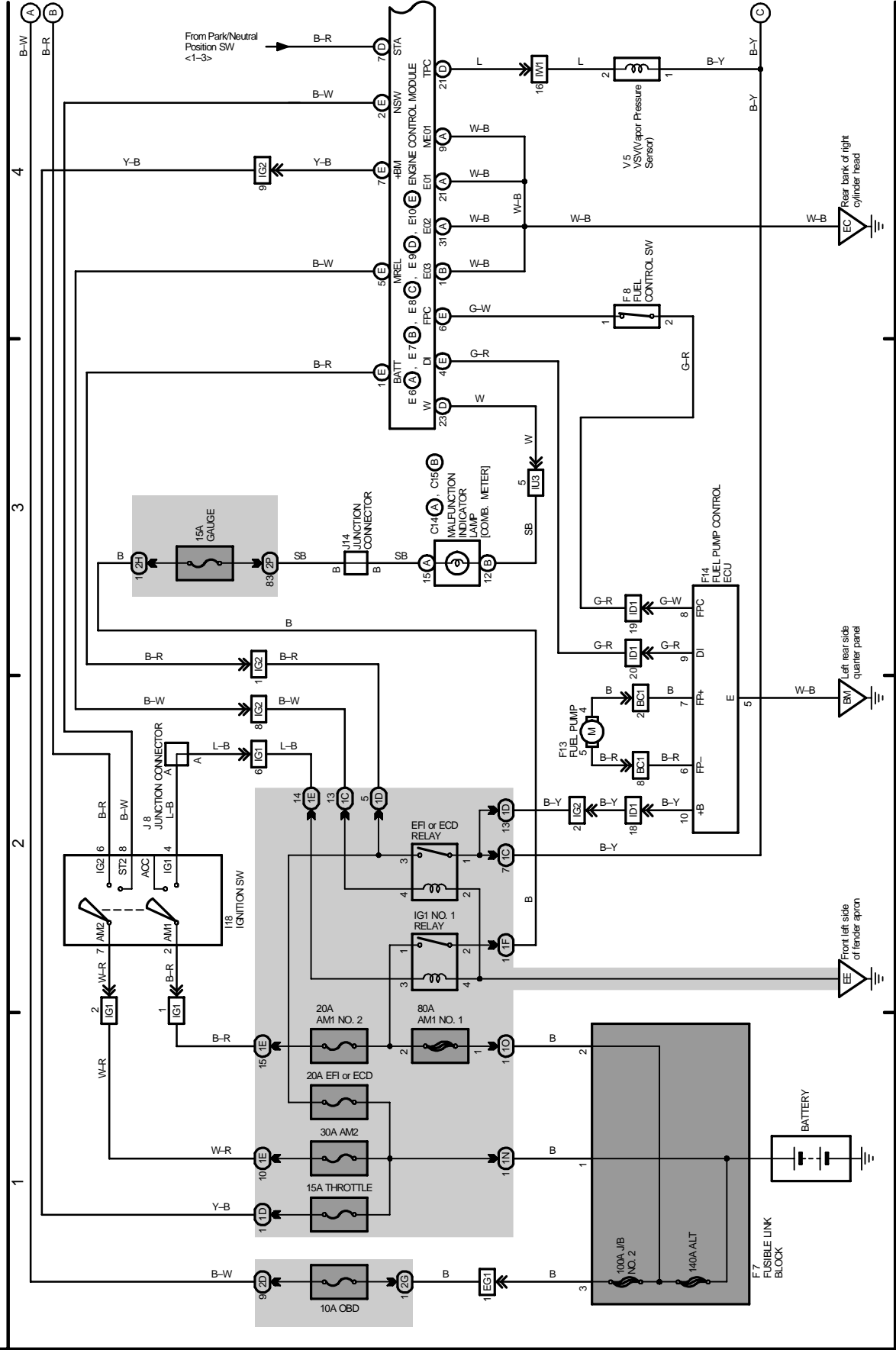

Engine Control and Engine Immobiliser System

\* 1: Shielded

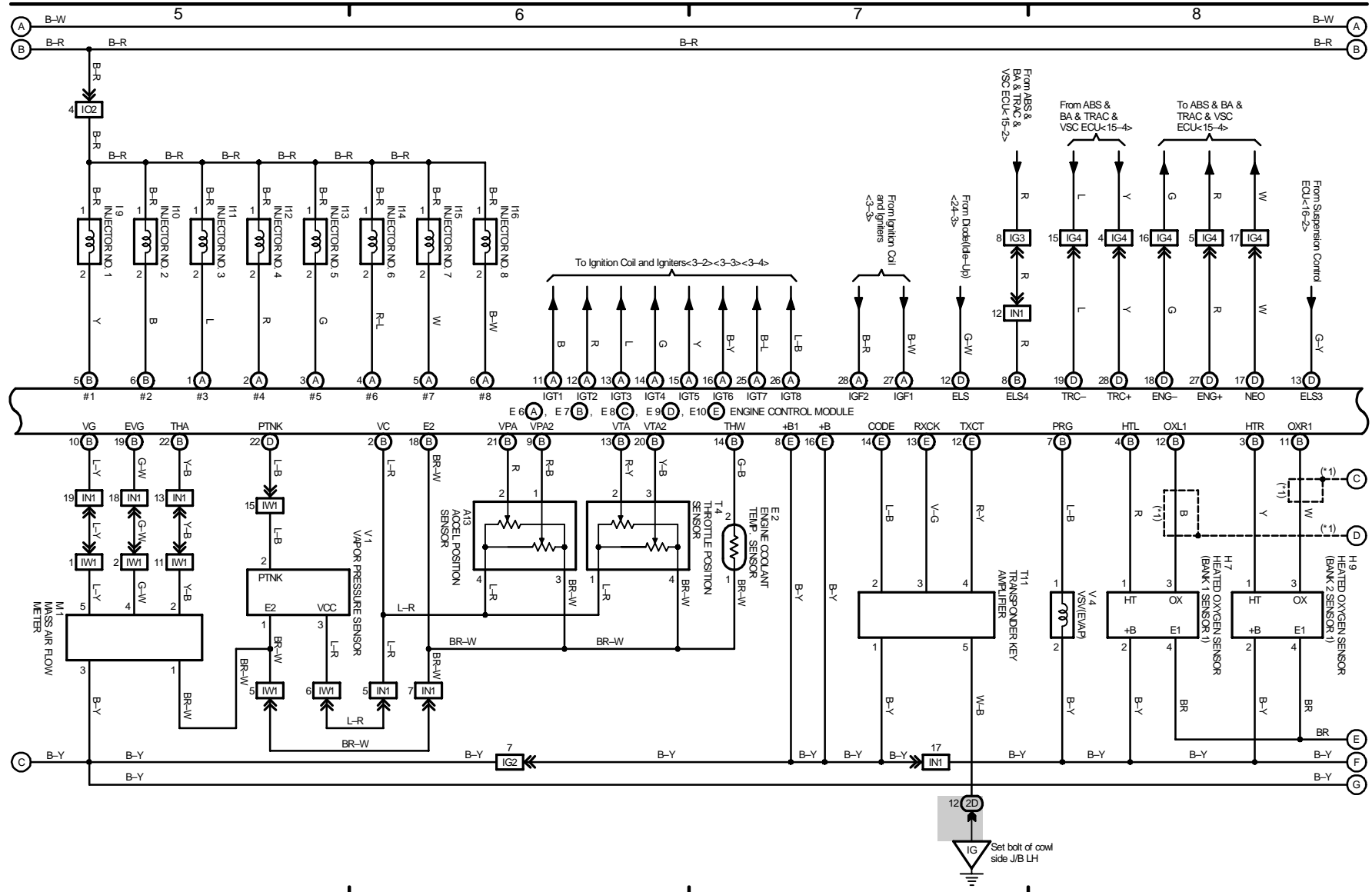

2001 LEXUS LX 470 (EWD427U)







Headlight

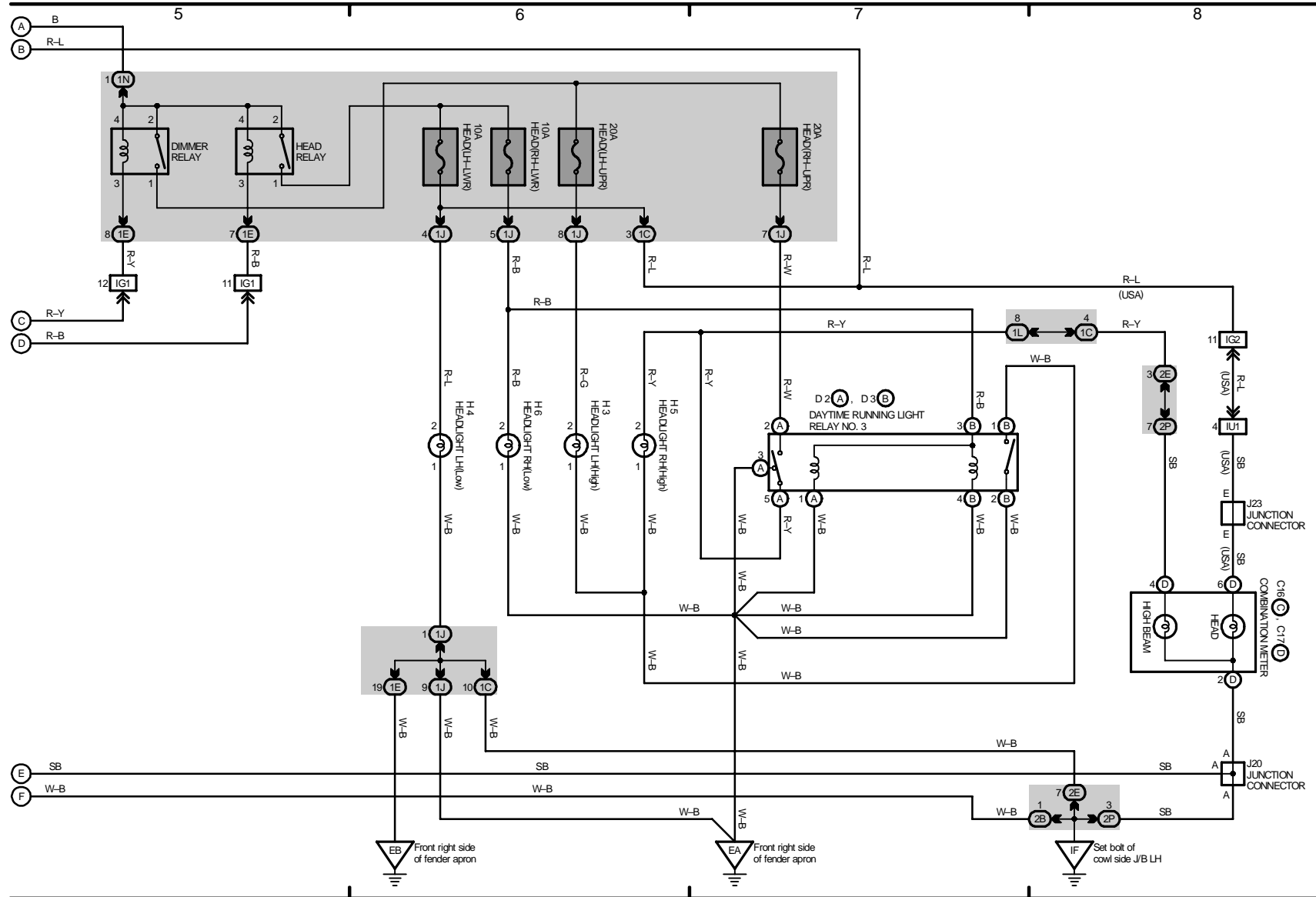

2001 LEXUS LX 470 (EWD427U)

# M OVERALL ELECTRICAL WIRING DIAGRAM

5 LX 470

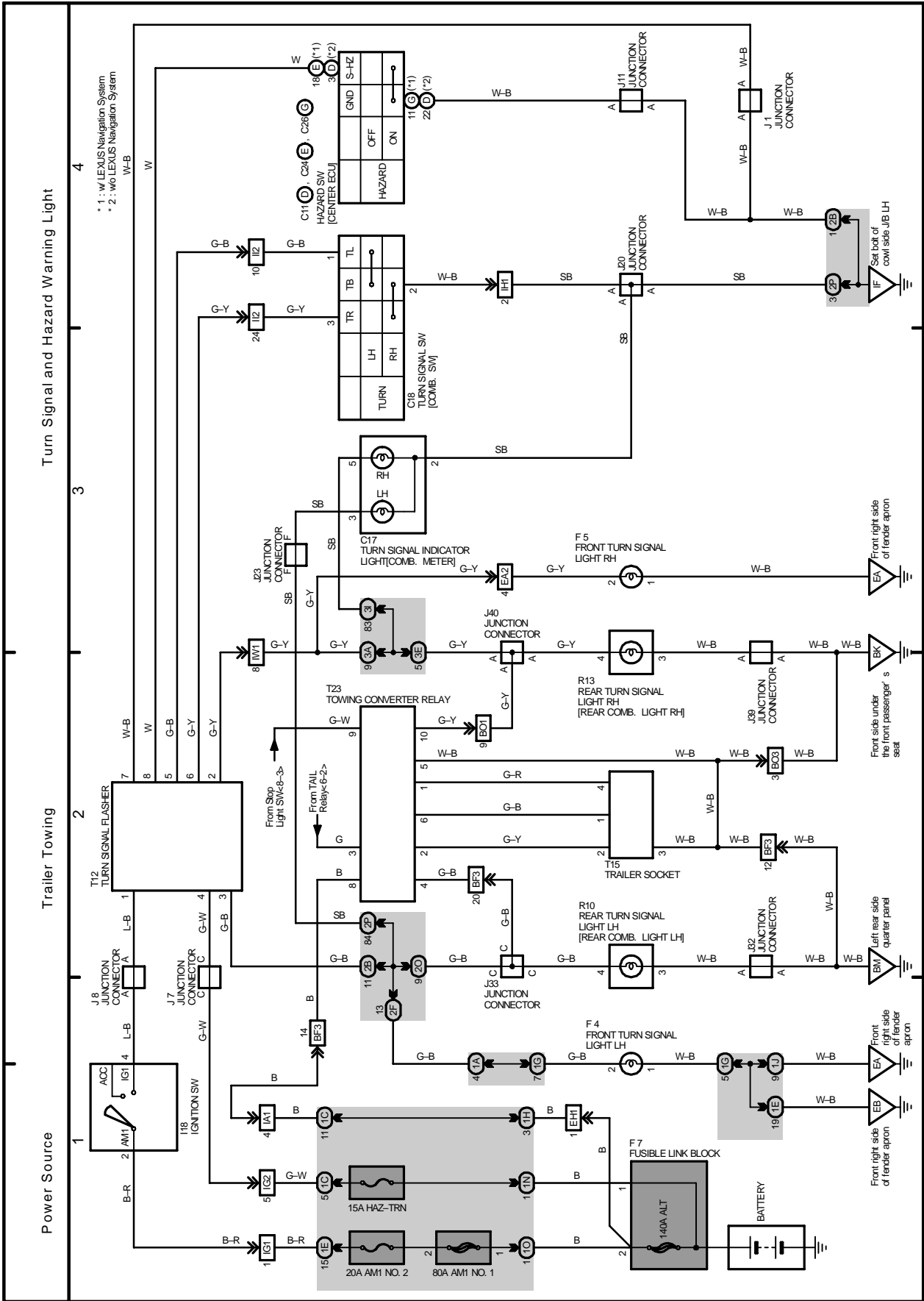

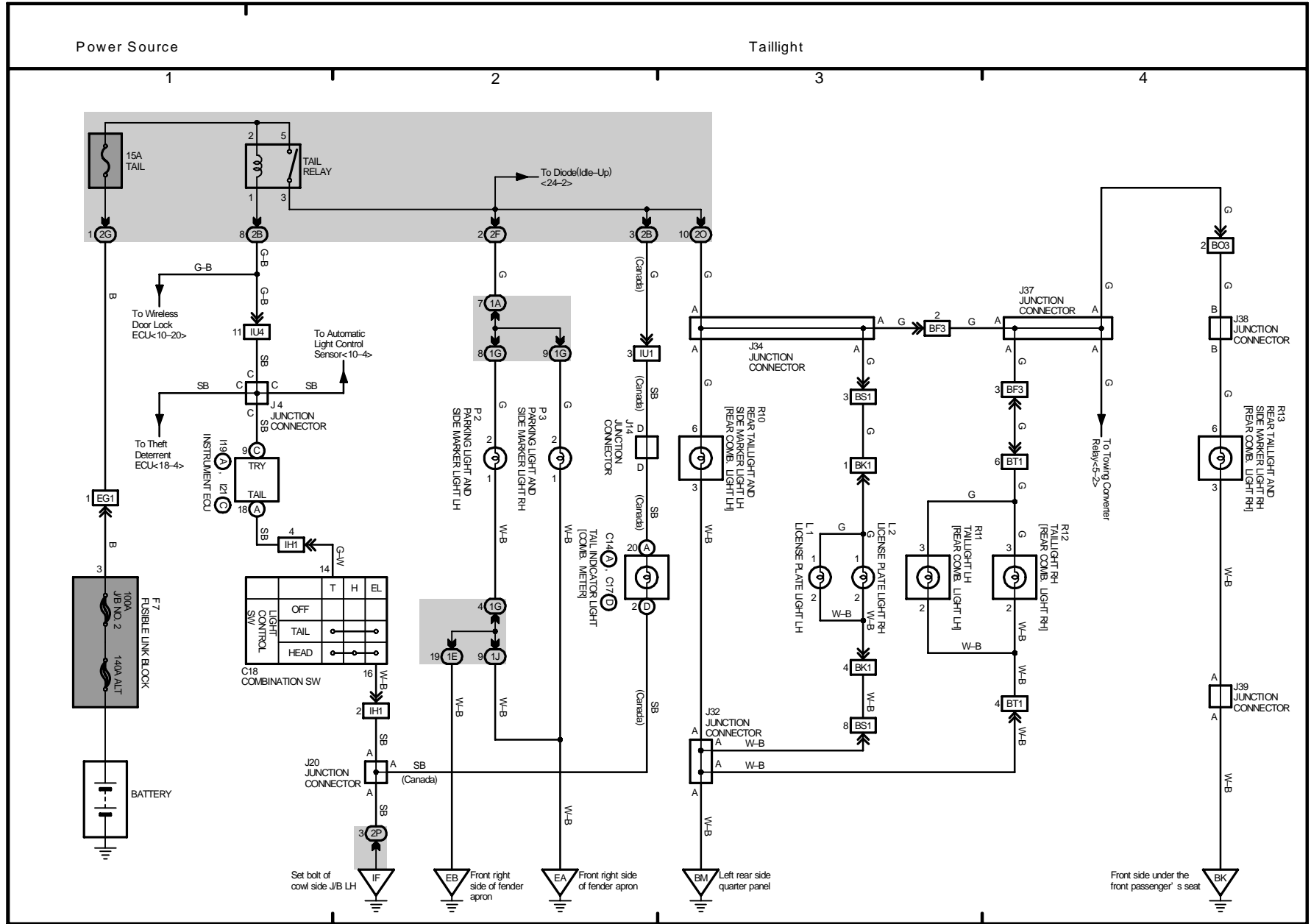

# M OVERALL ELECTRICAL WIRING DIAGRAM

(Cont. next page)

7 LX 470

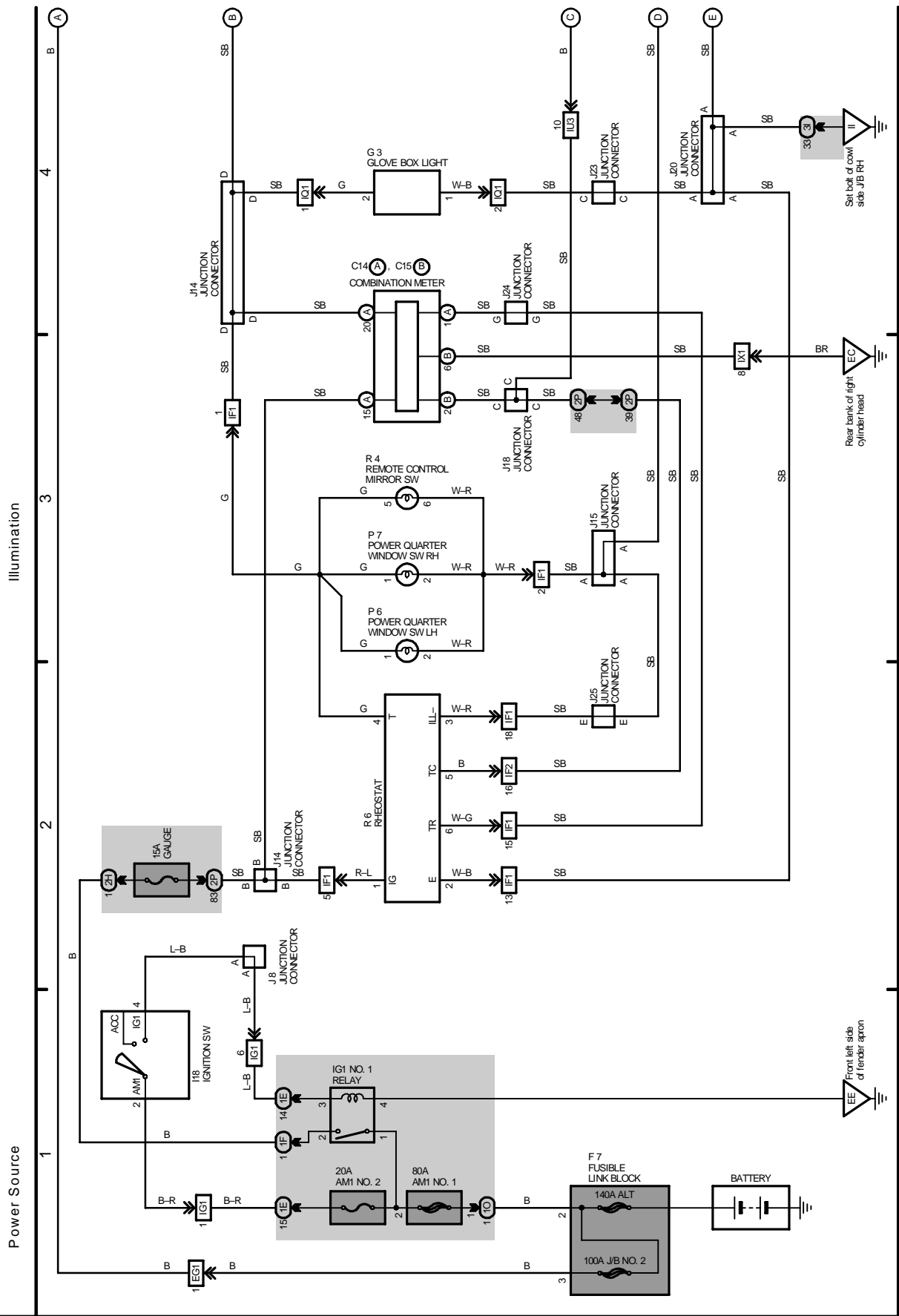

7 LX 470 (Cont' d)

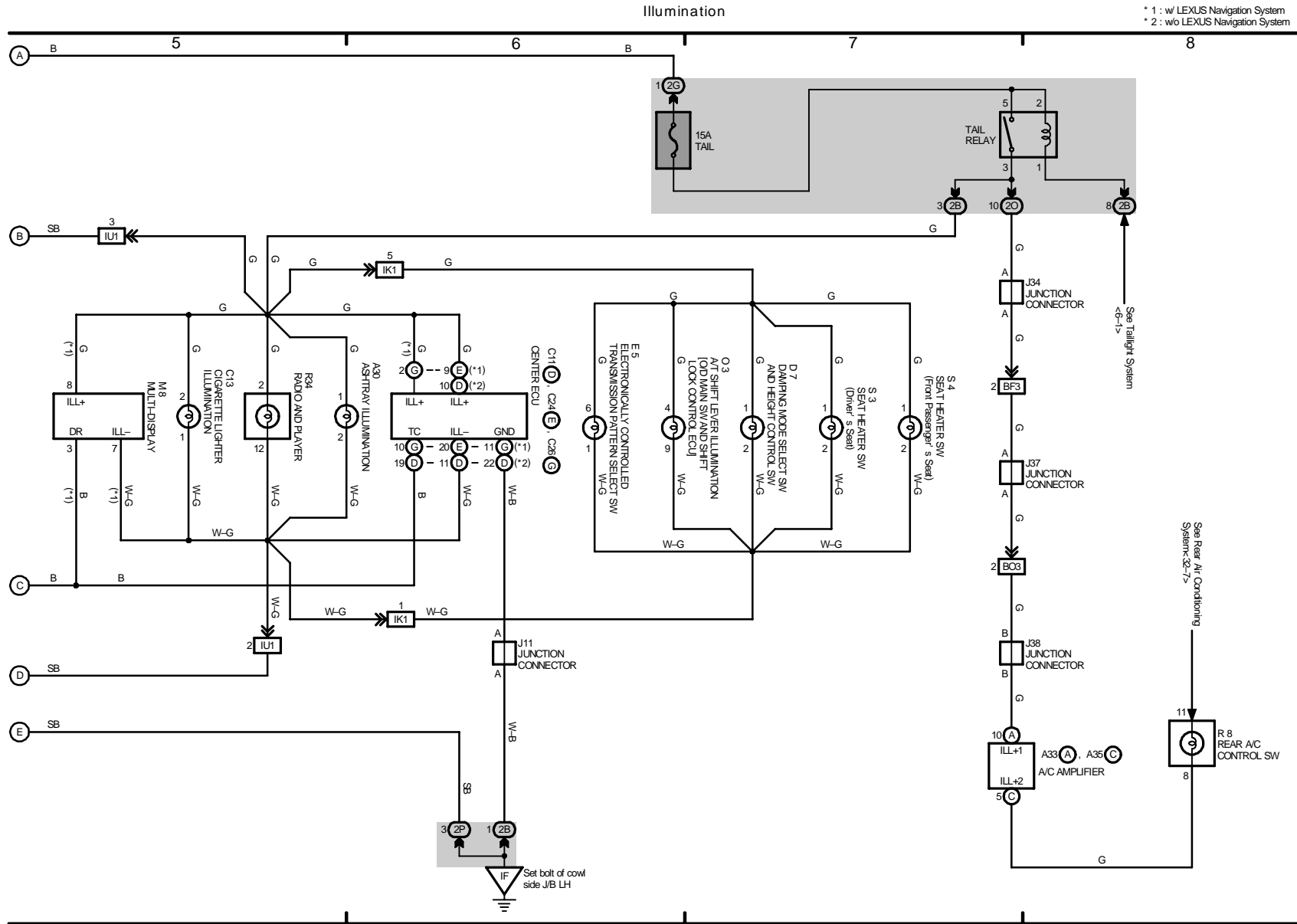

2001 LEXUS LX 470 (EWD427U)

# M OVERALL ELECTRICAL WIRING DIAGRAM

8 LX 470

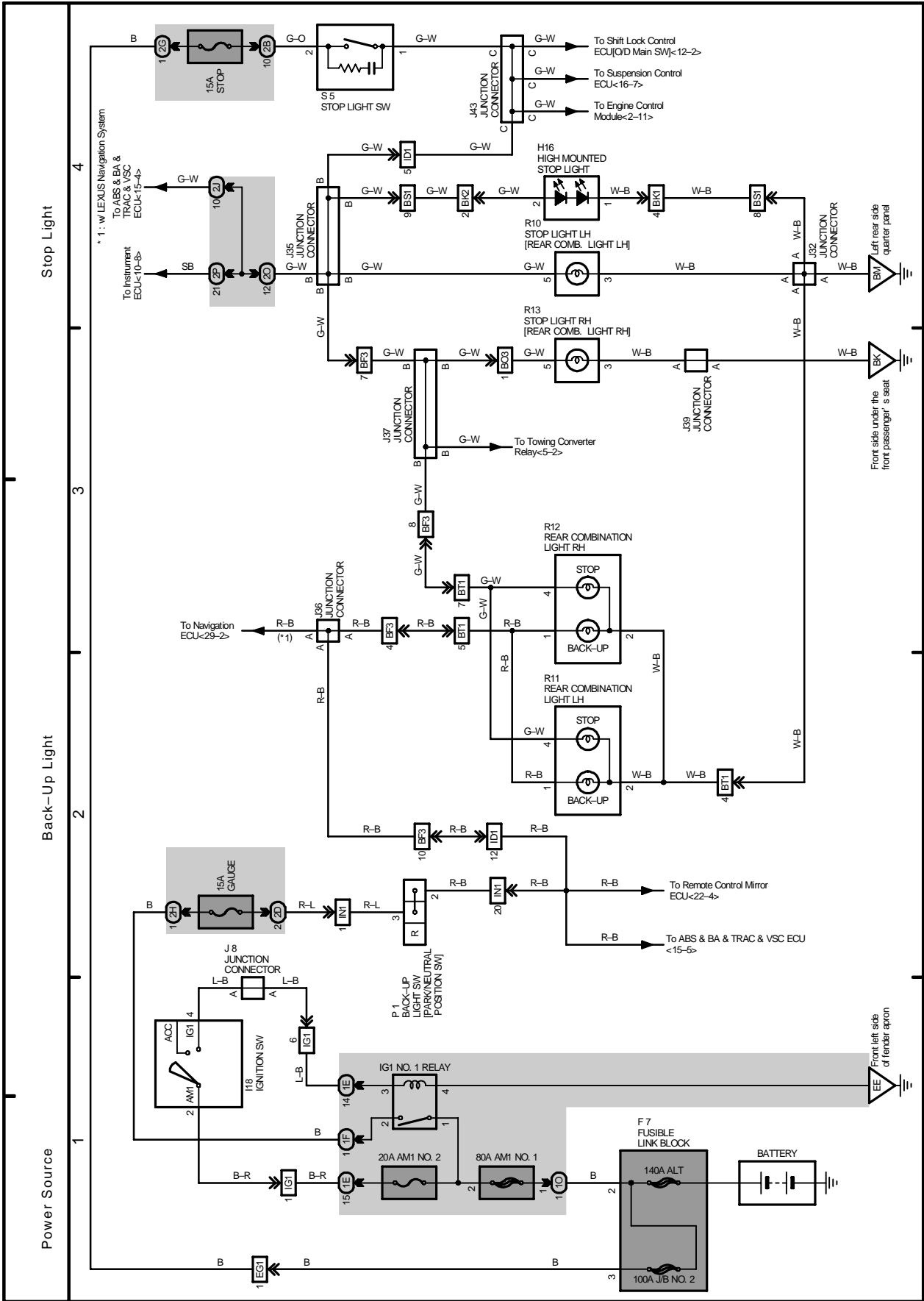

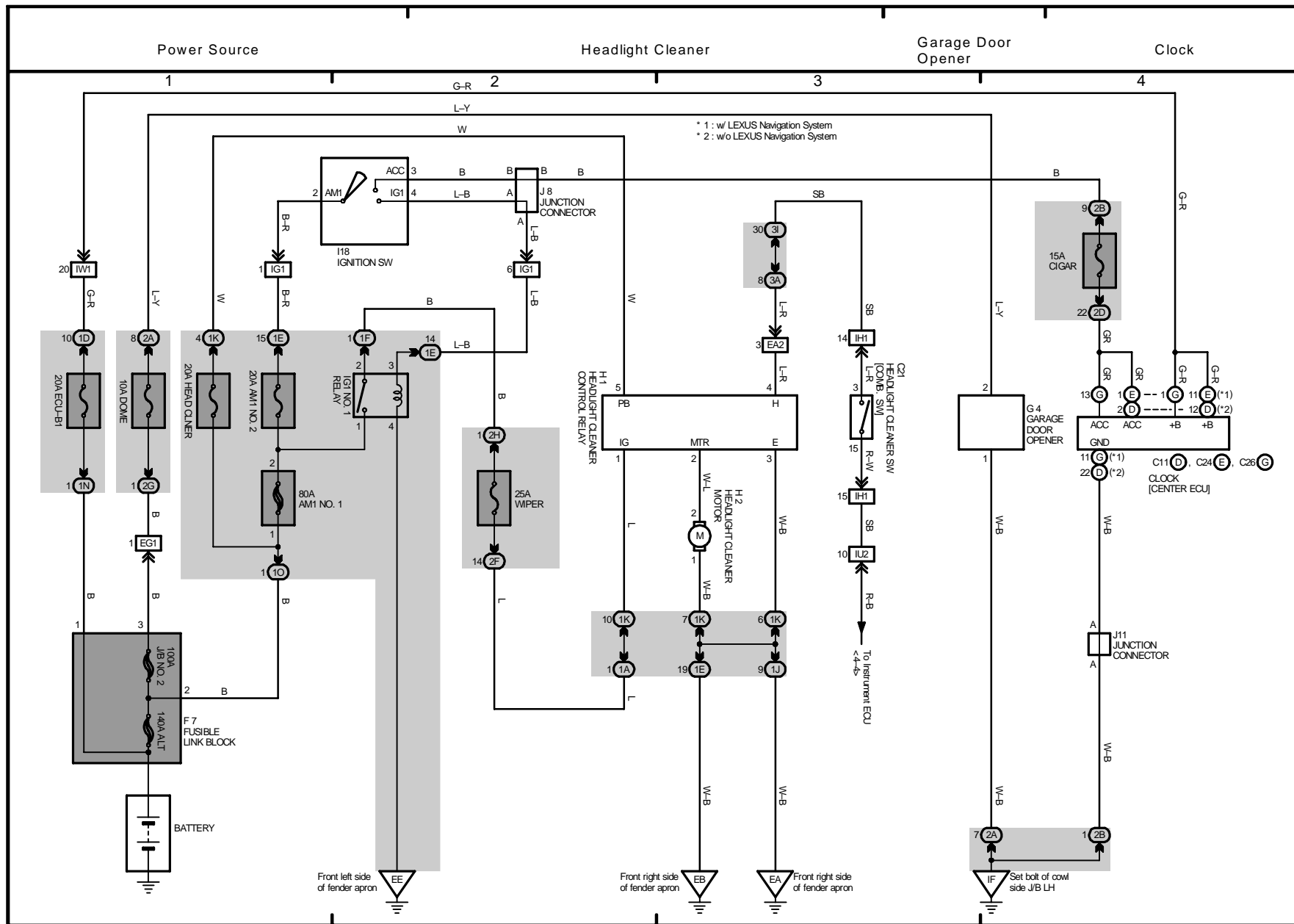



Multiplex Communication System

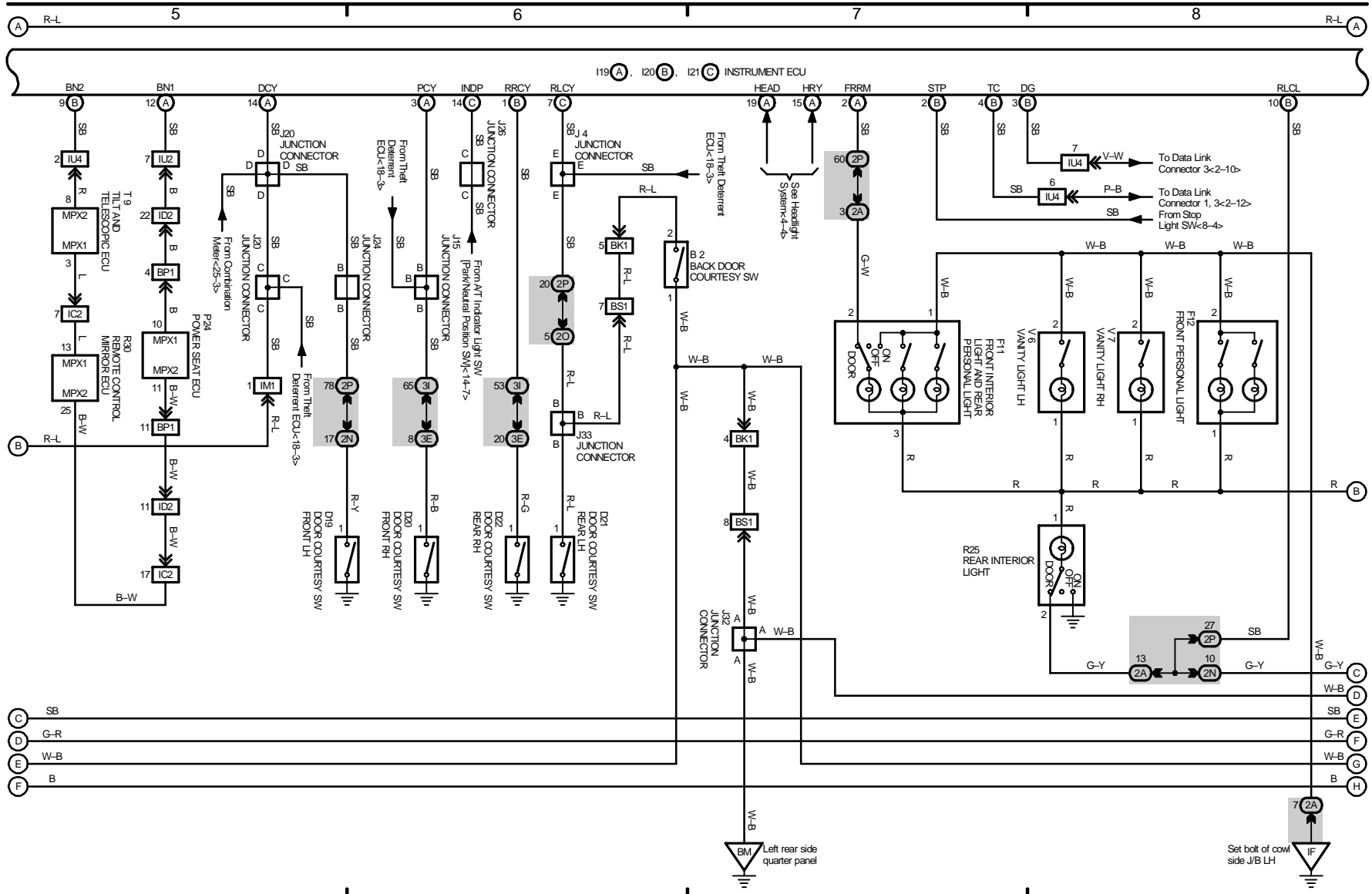

2001 LEXUS LX 470 (EWD427U)



Multiplex Communication System

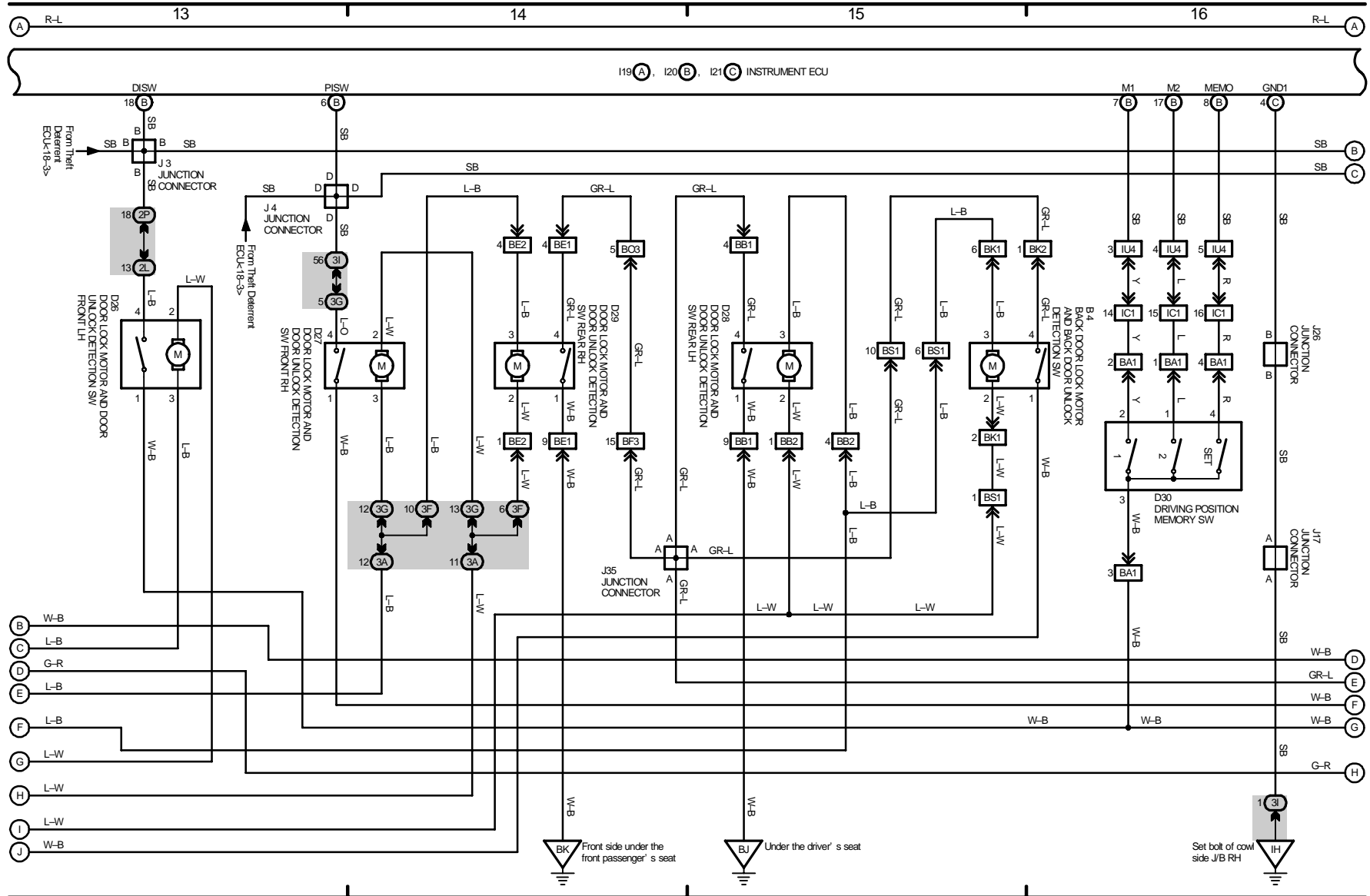

2001 LEXUS LX 470 (EWD427U)



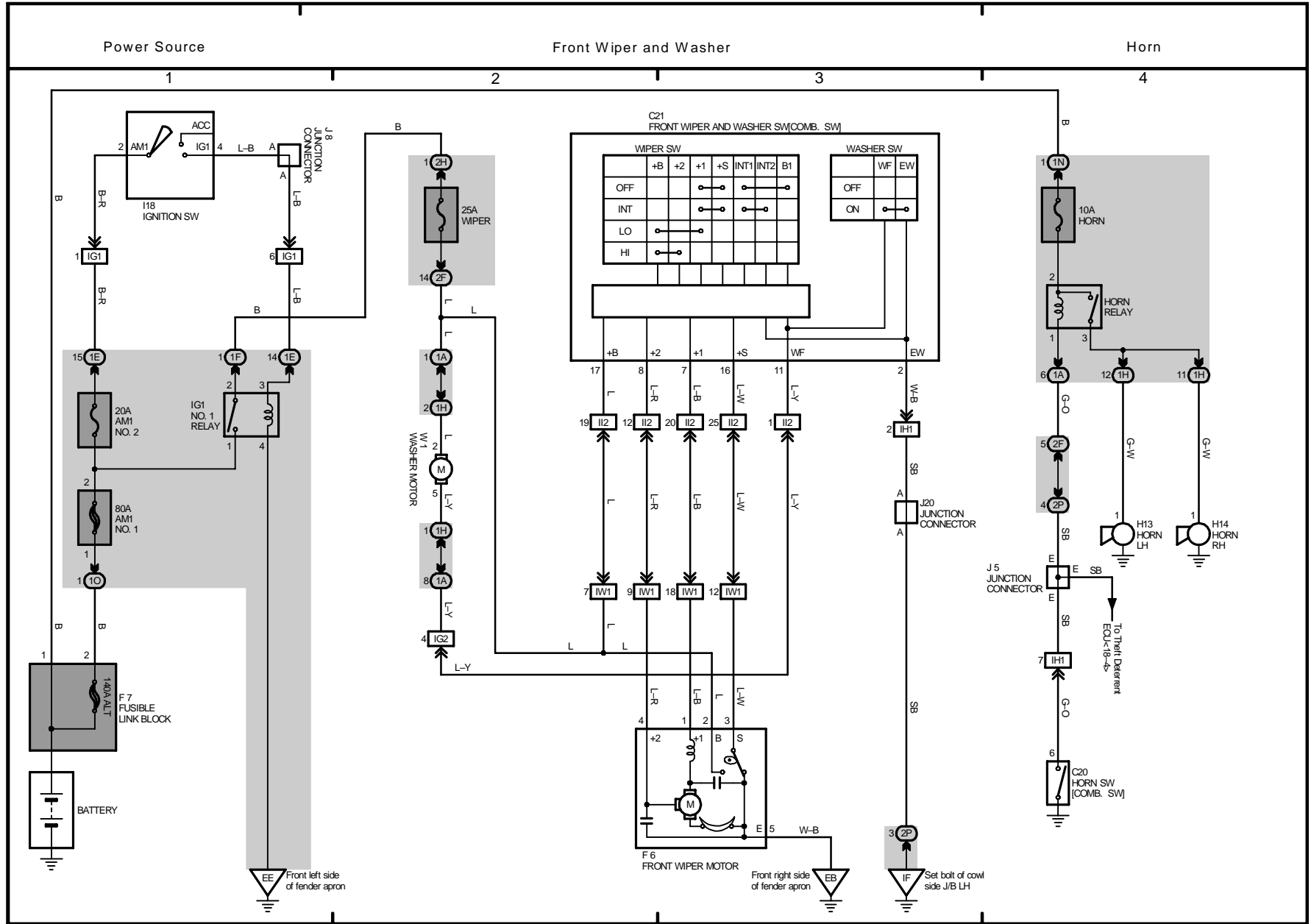

# M OVERALL ELECTRICAL WIRING DIAGRAM

12 LX 470

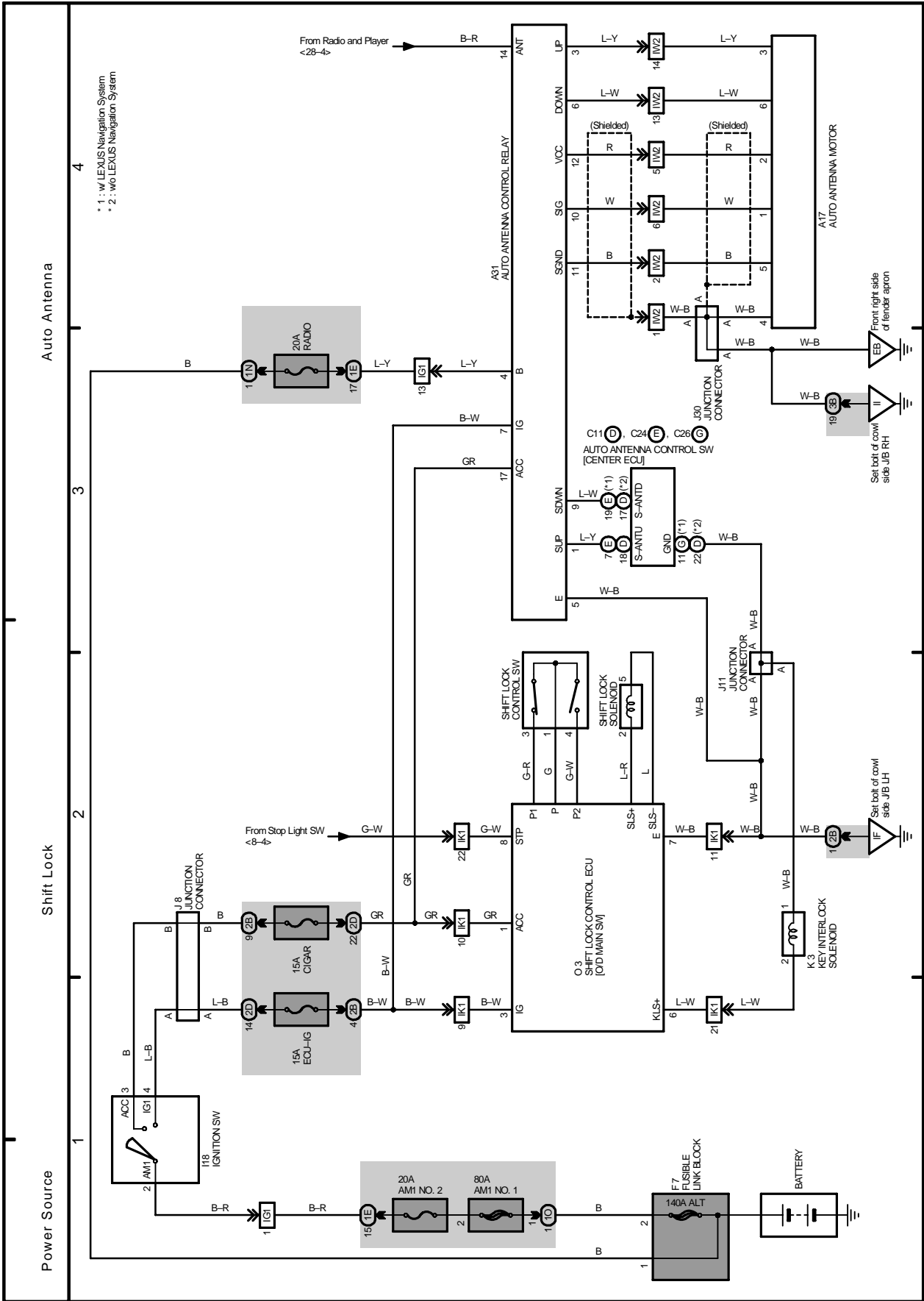



# M OVERALL ELECTRICAL WIRING DIAGRAM

(Cont. next page)

14 LX 470

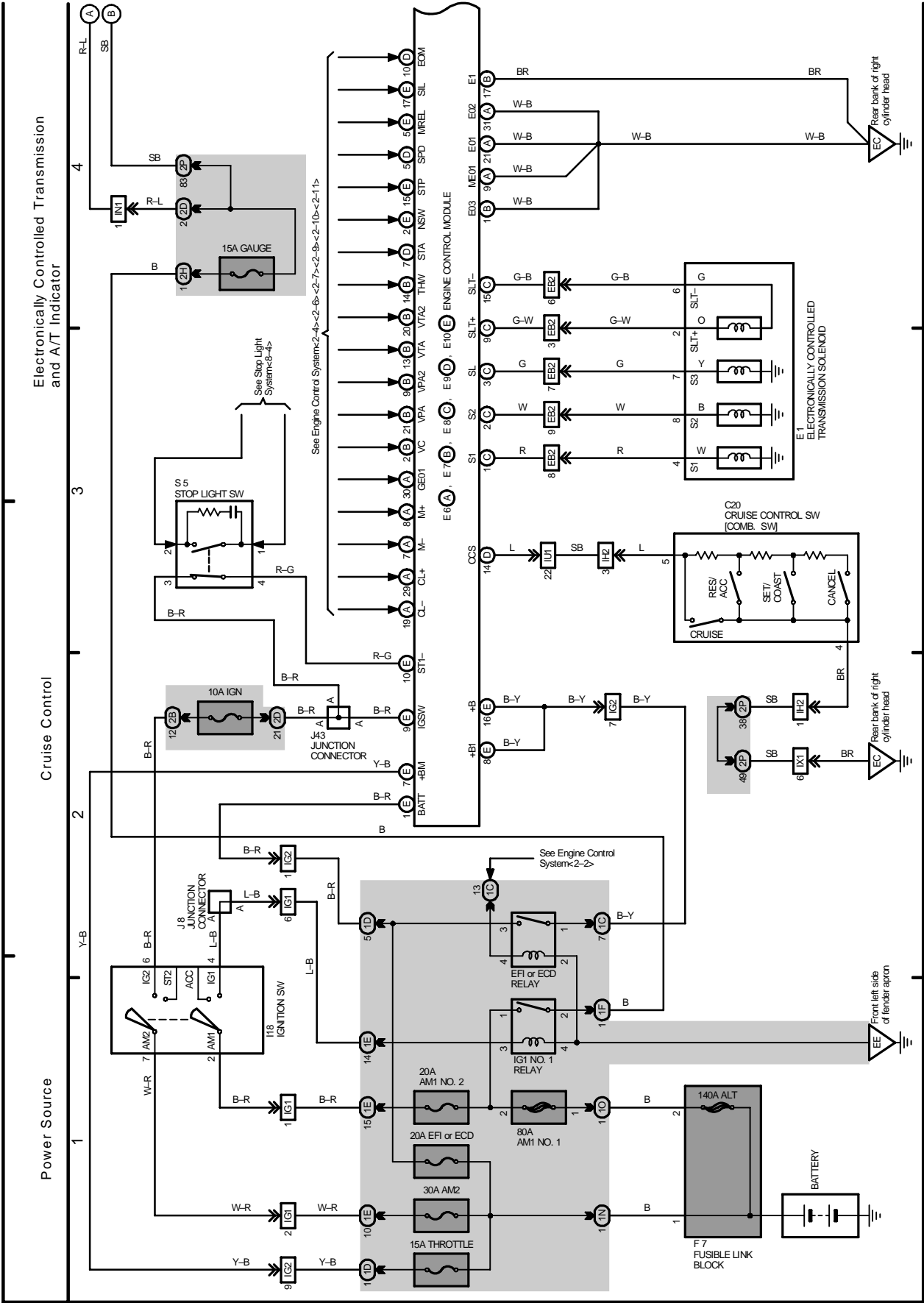

Electronically Controlled Transmission and A/T Indicator

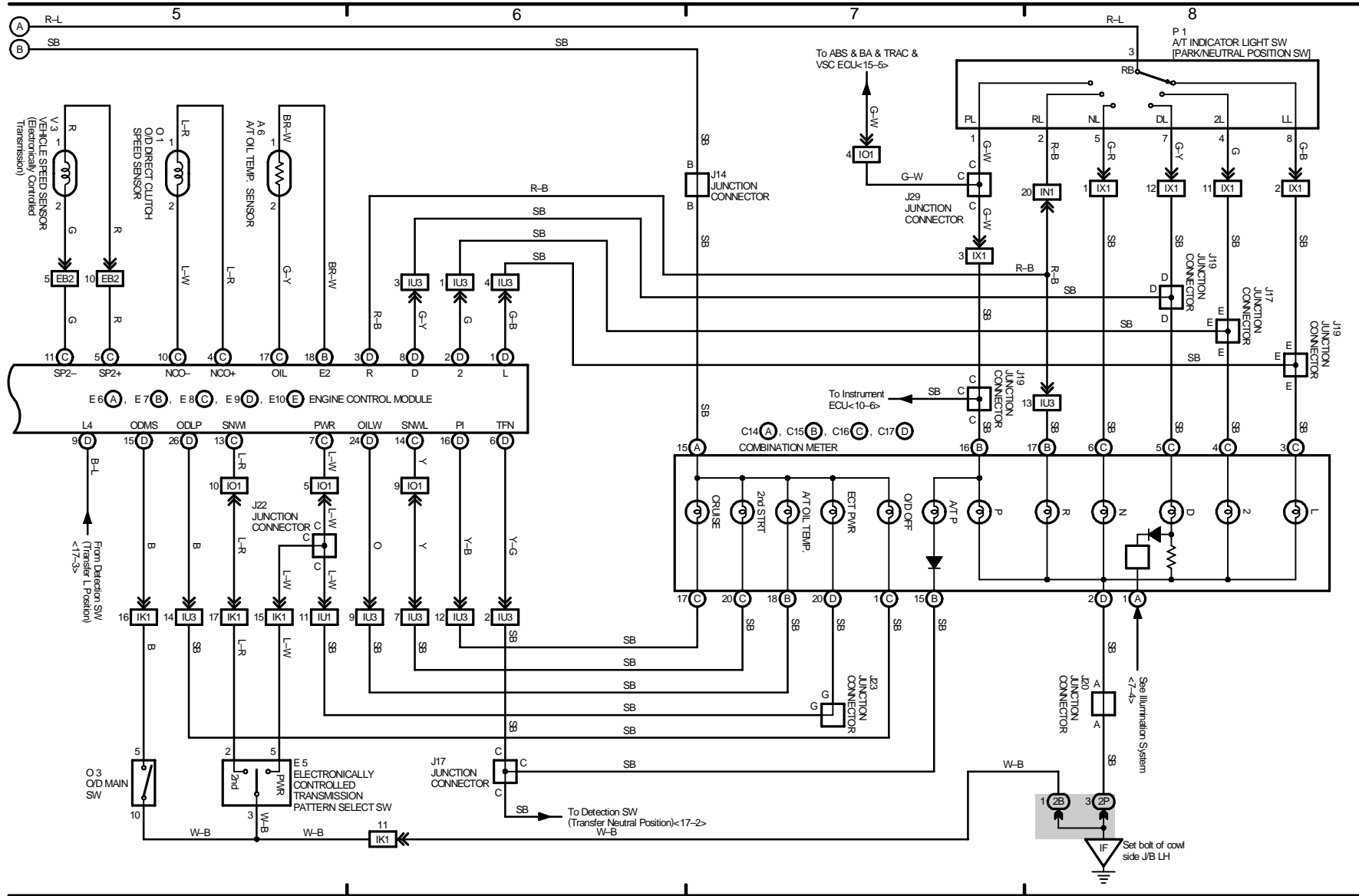

2001 LEXUS LX 470 (EMD427U)

# M OVERALL ELECTRICAL WIRING DIAGRAM

(Cont. next page)

15 LX 470

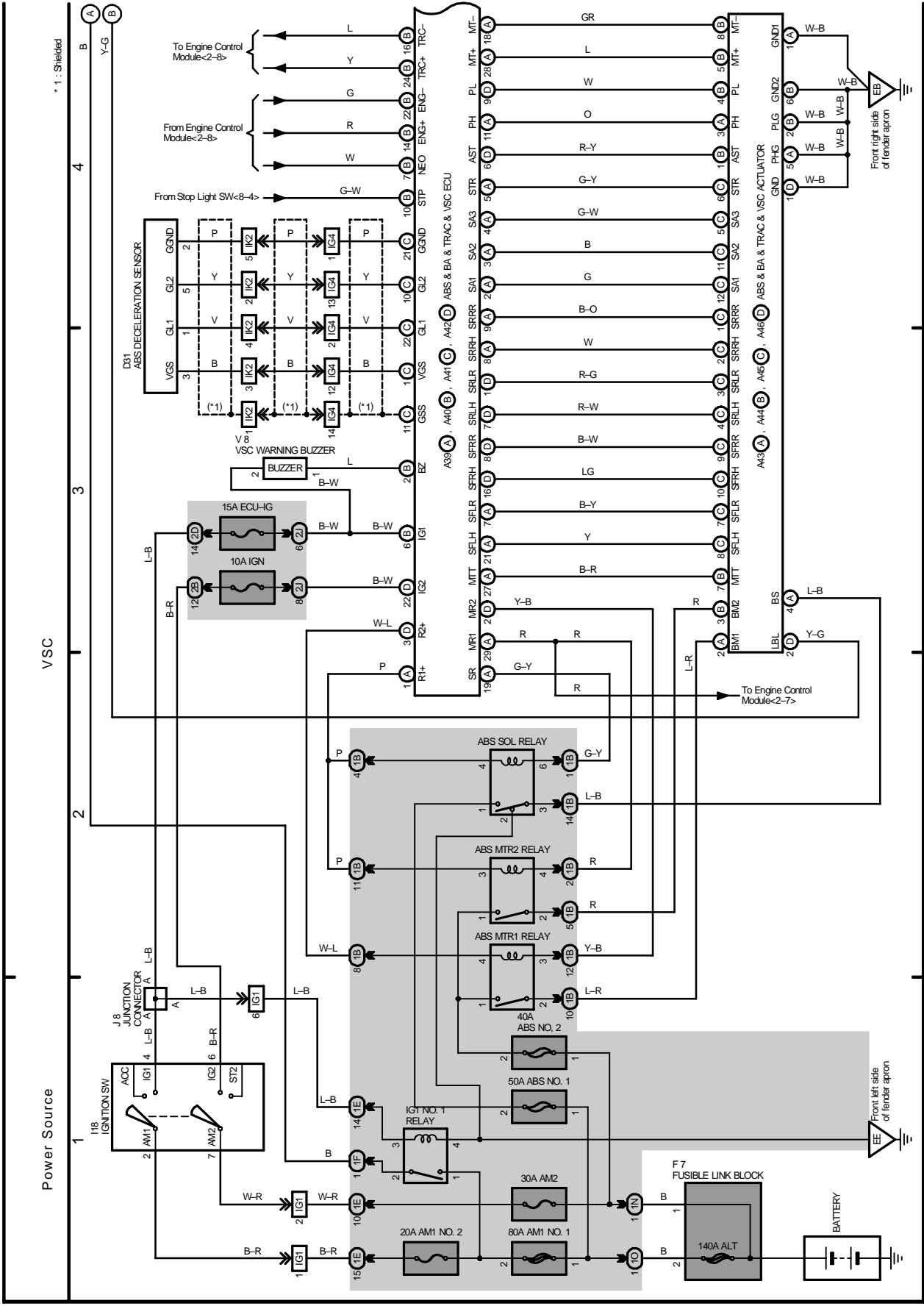



# M OVERALL ELECTRICAL WIRING DIAGRAM

15 LX 470 (Cont' d)

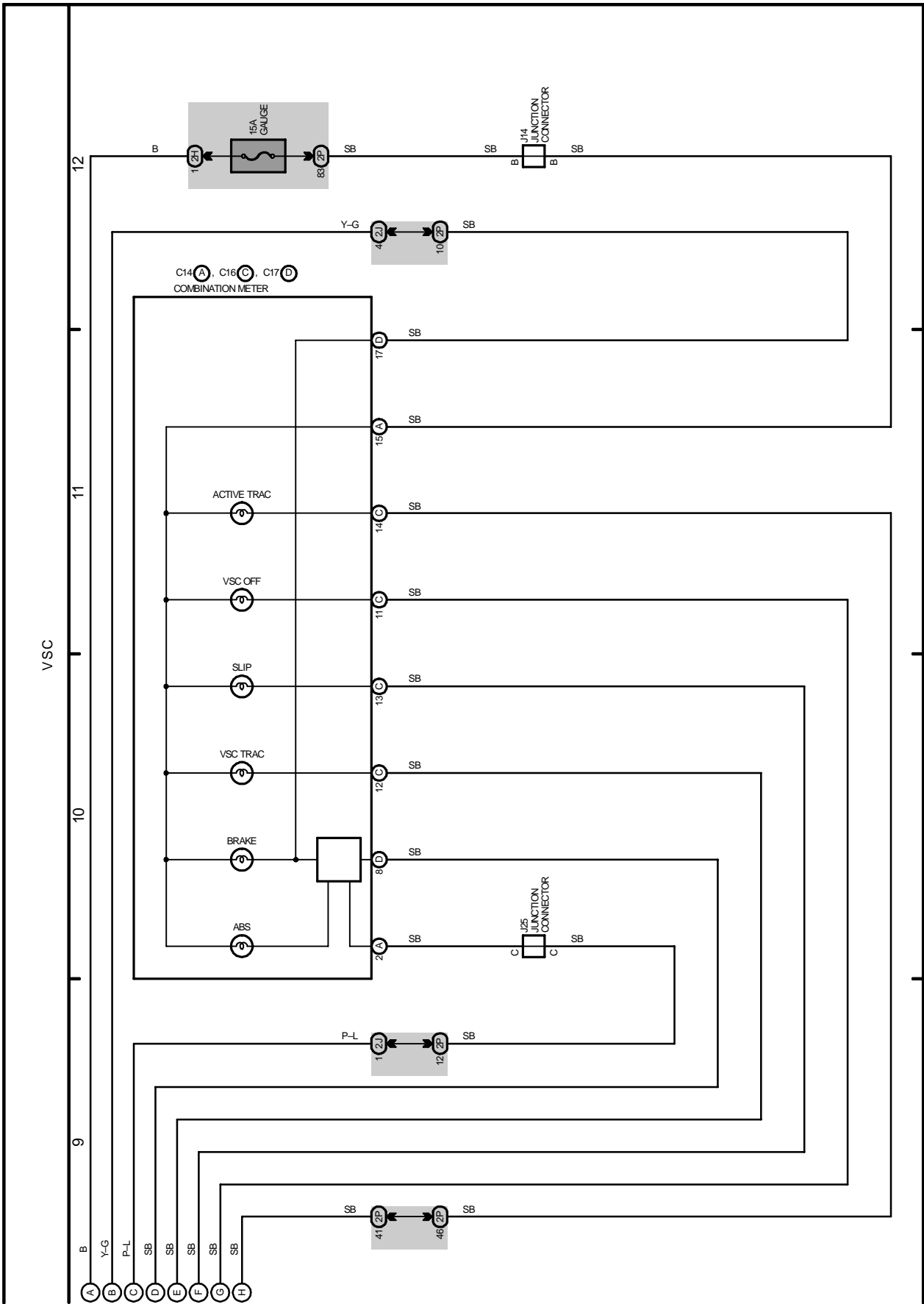



# M OVERALL ELECTRICAL WIRING DIAGRAM

(Cont. next page)

## Active Height Control Suspension and Adaptive Variable Suspension

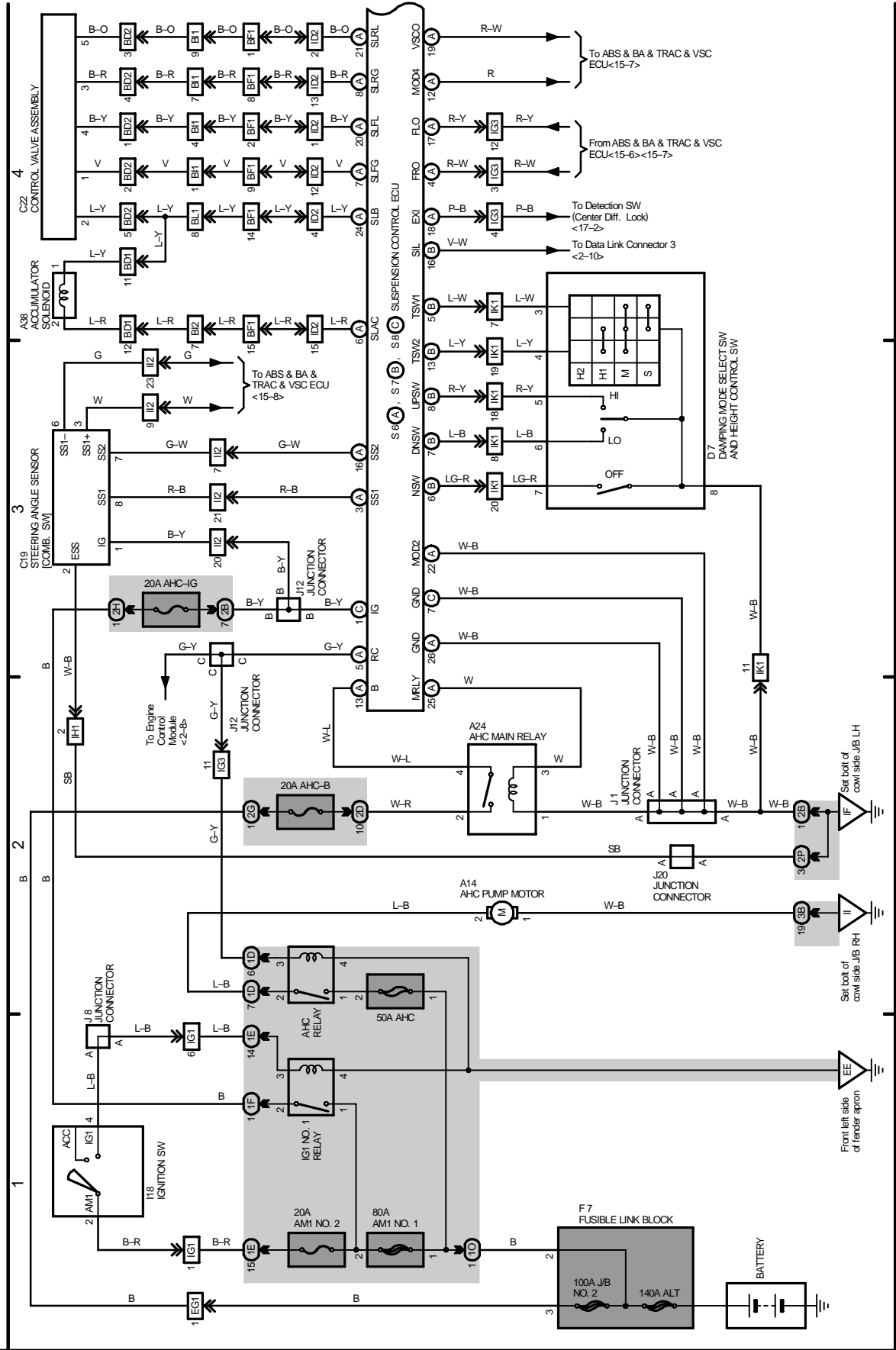

16 LX 470

Active Height Control Suspension and Adaptive Variable Suspension

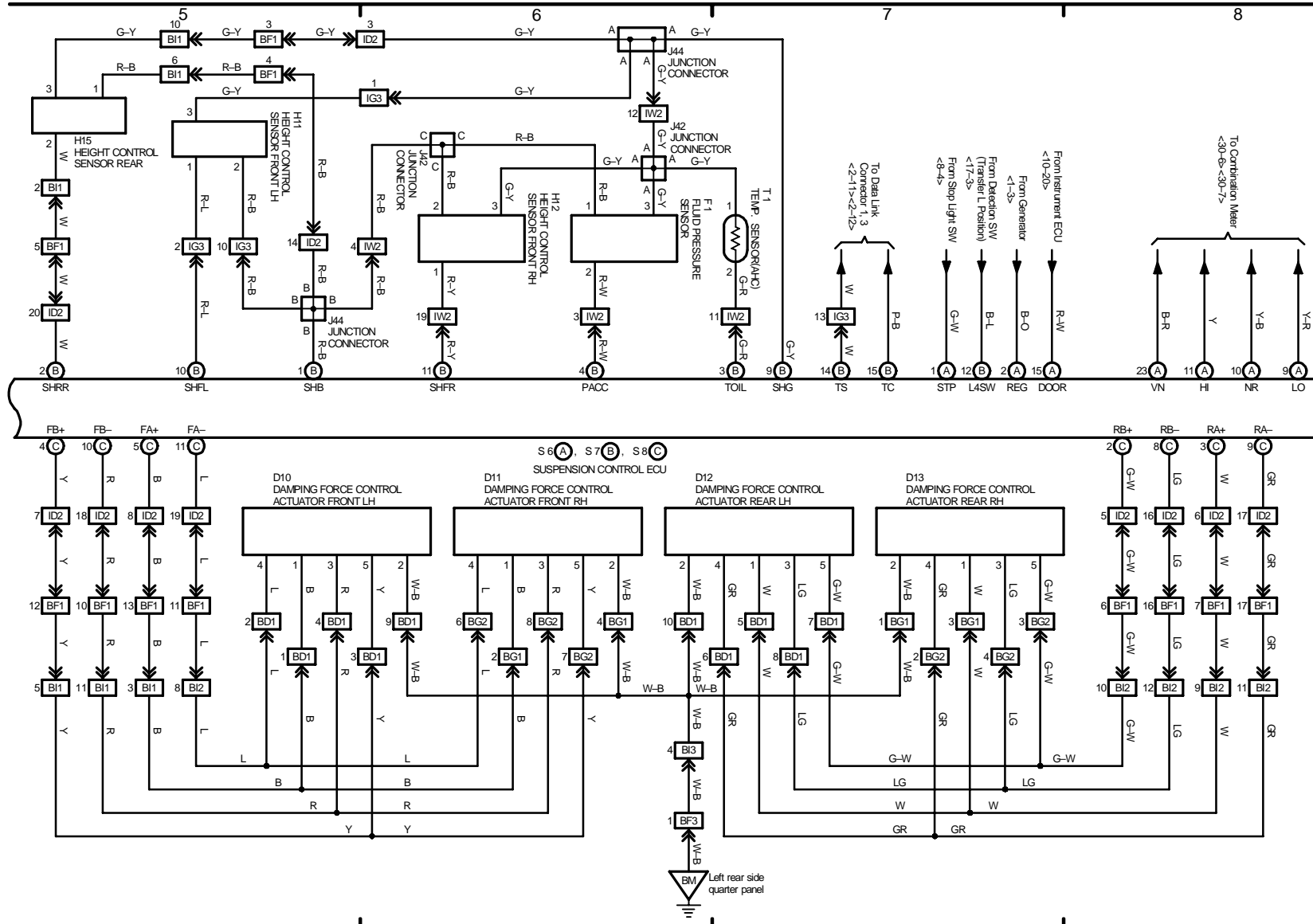

2001 LEXUS LX 470 (EWD427U)





# M OVERALL ELECTRICAL WIRING DIAGRAM

19 LX 470

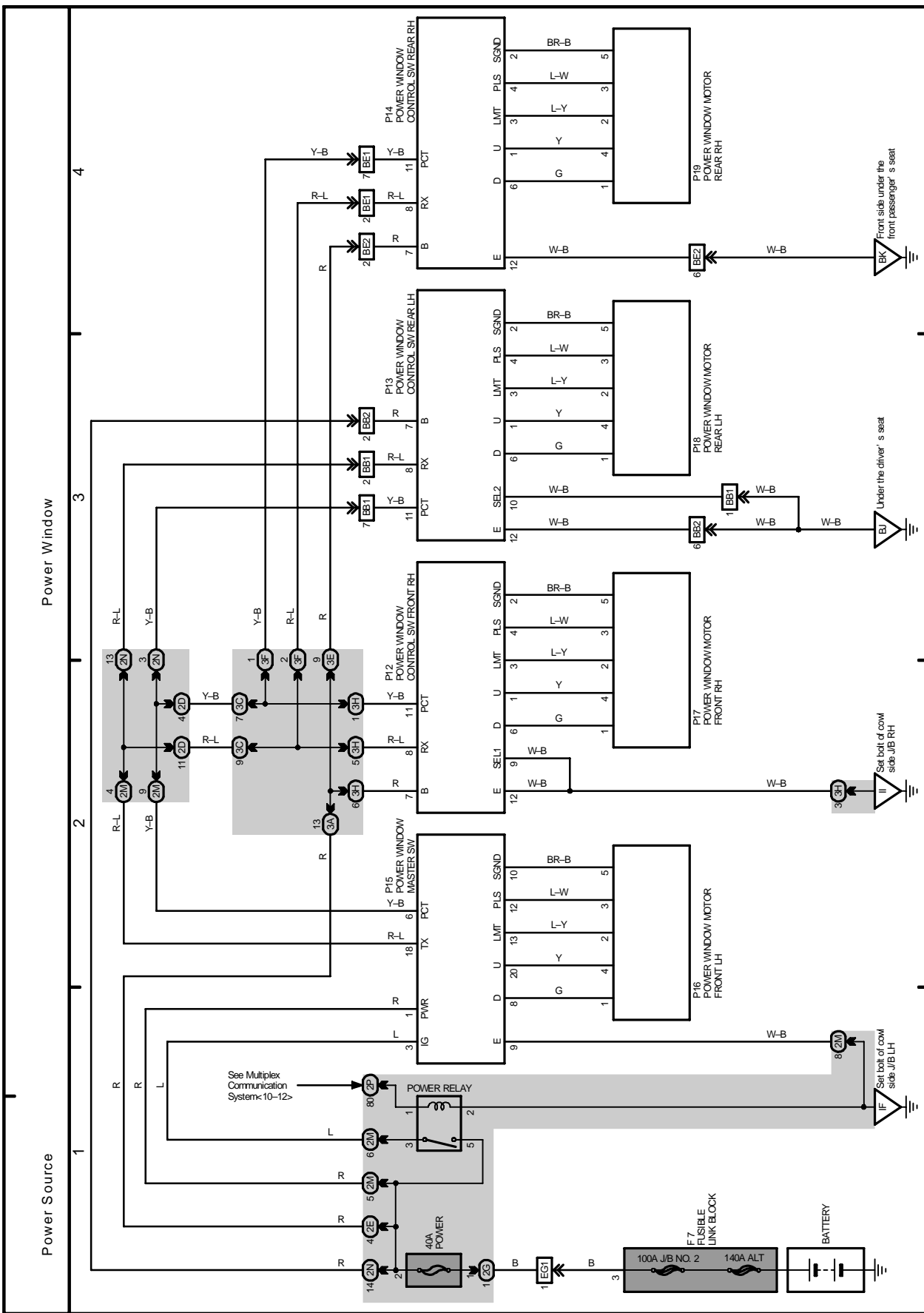





Power Seat

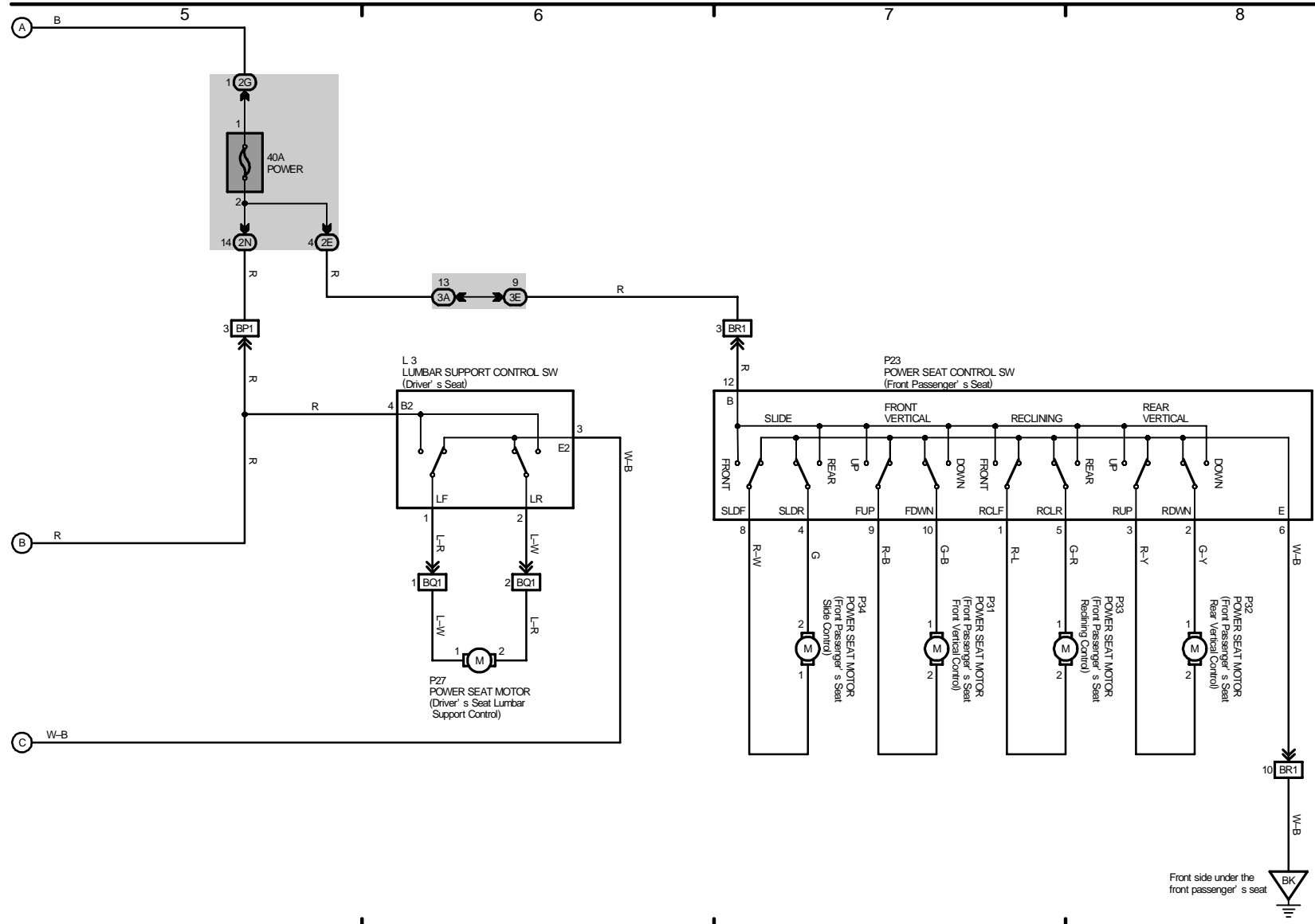

2001 LEXUS LX 470 (EMD427U)

# M OVERALL ELECTRICAL WIRING DIAGRAM

21 LX 470

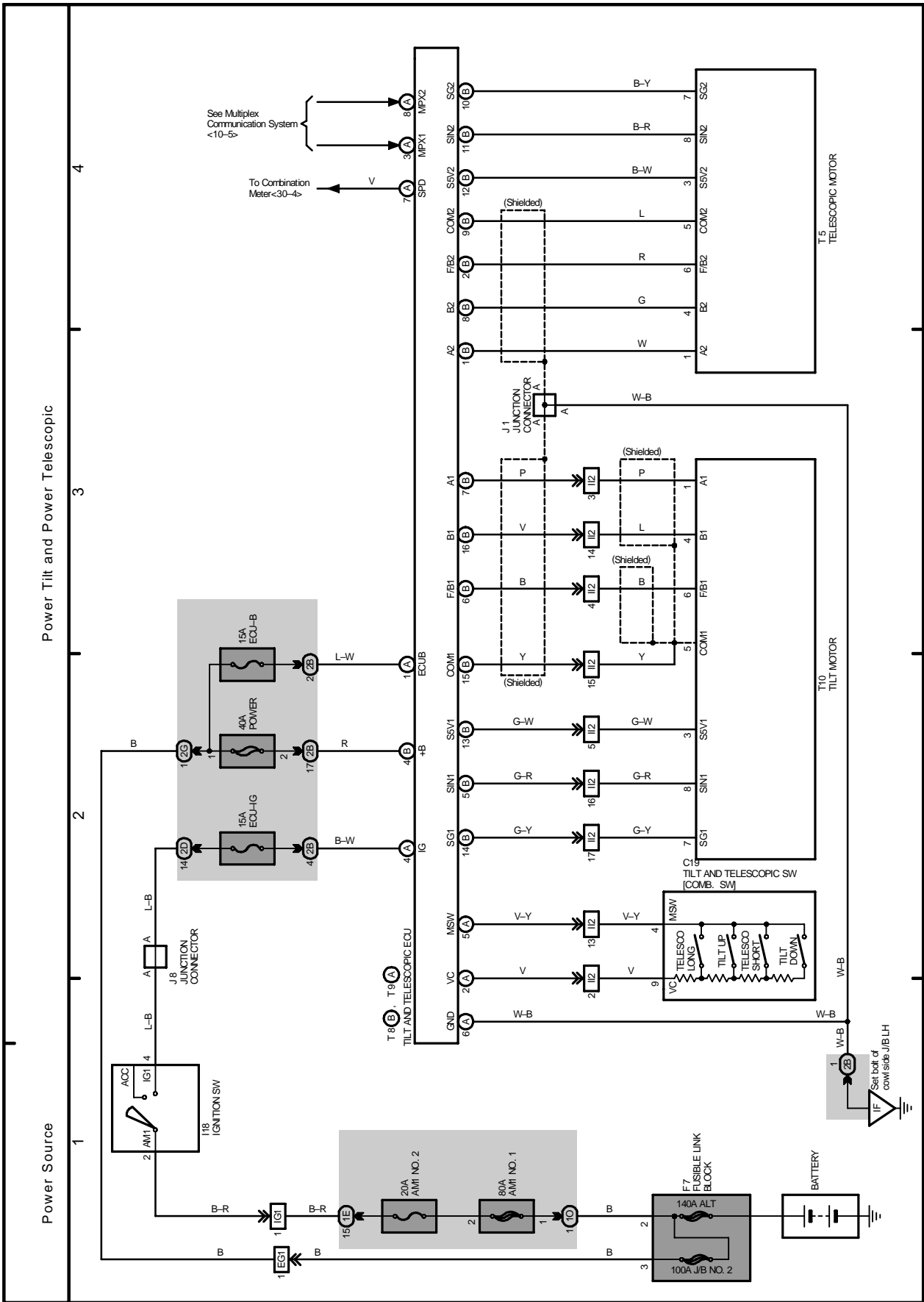

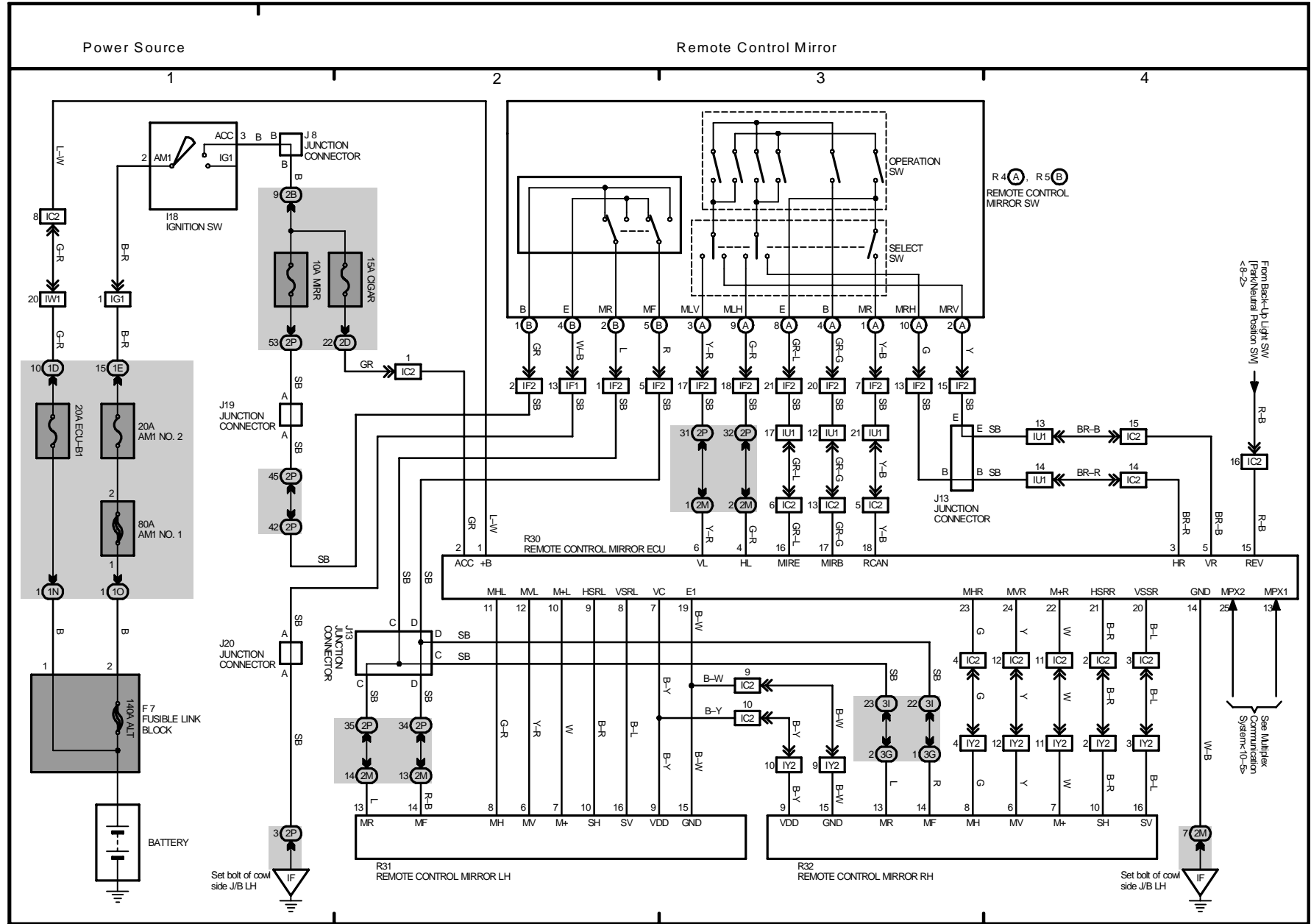

# M OVERALL ELECTRICAL WIRING DIAGRAM

23 LX 470

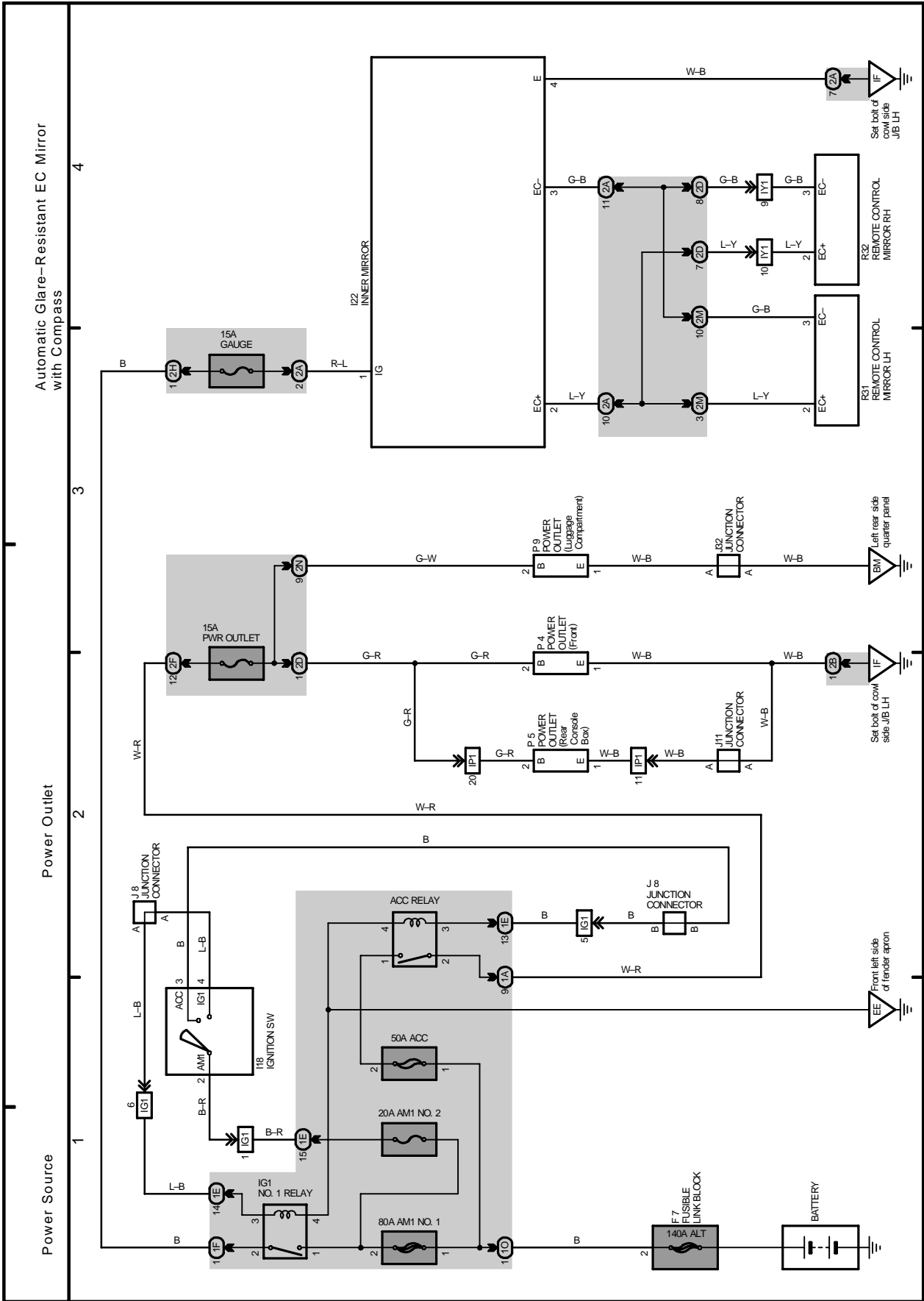

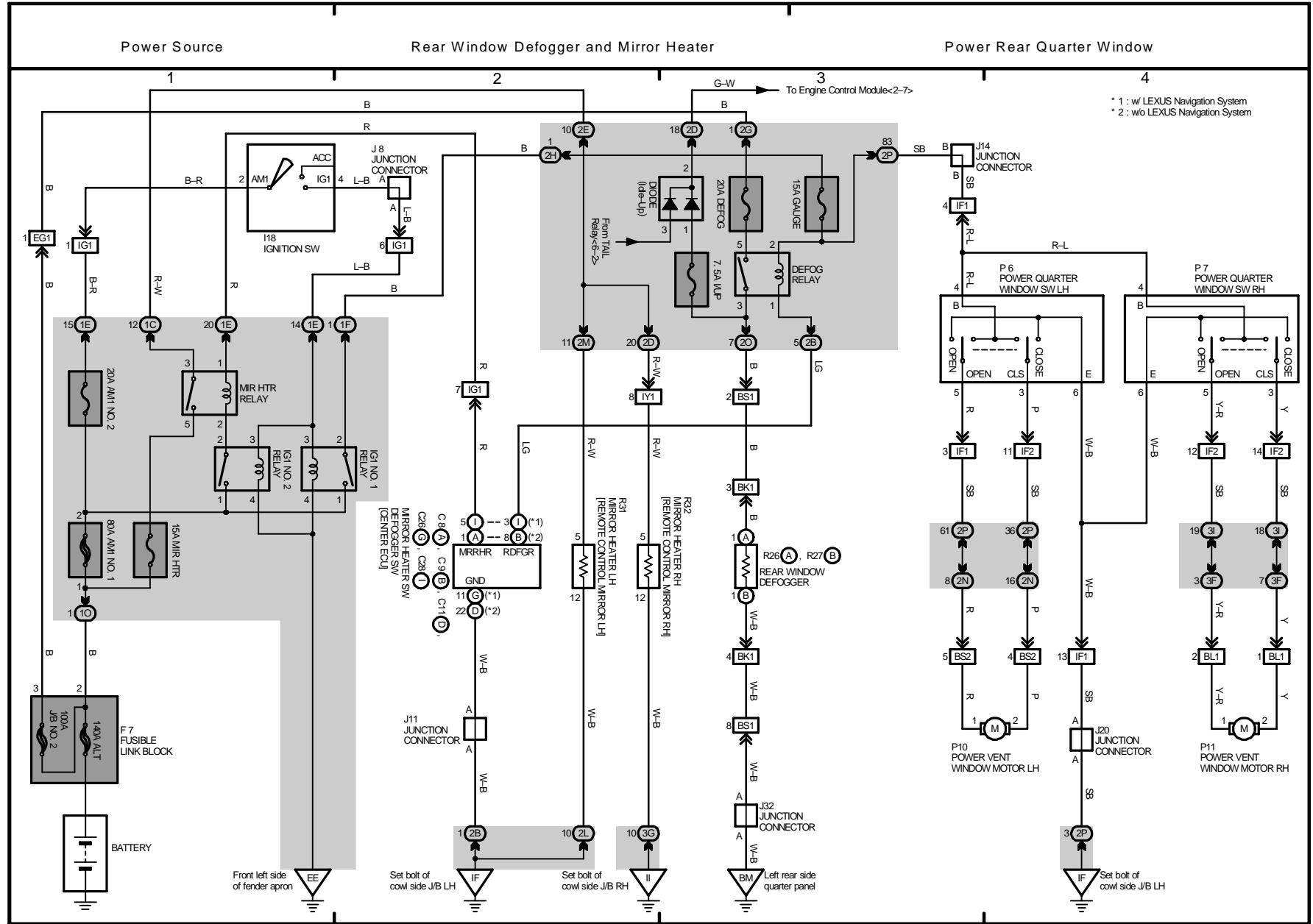

# M OVERALL ELECTRICAL WIRING DIAGRAM

25 LX 470

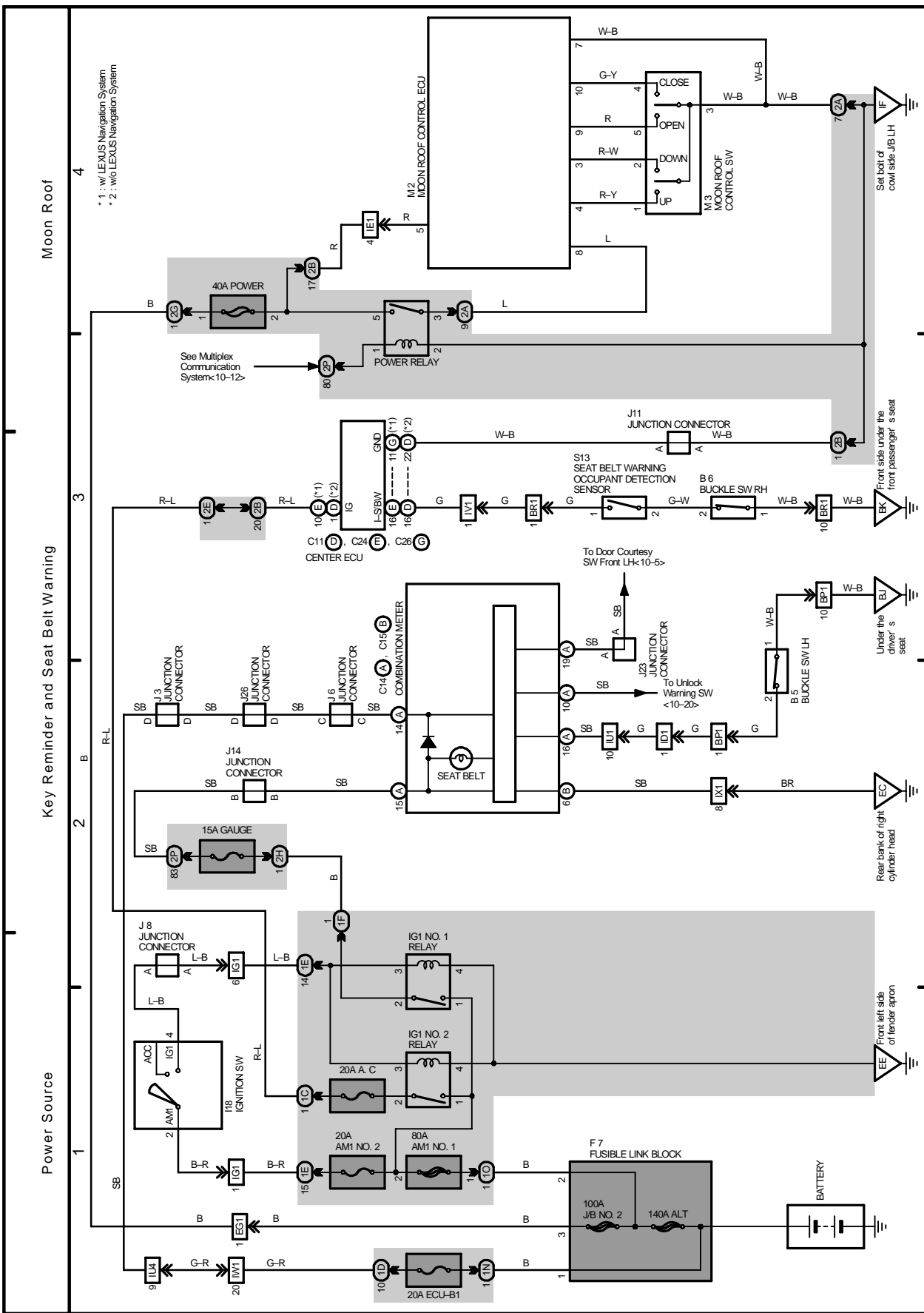

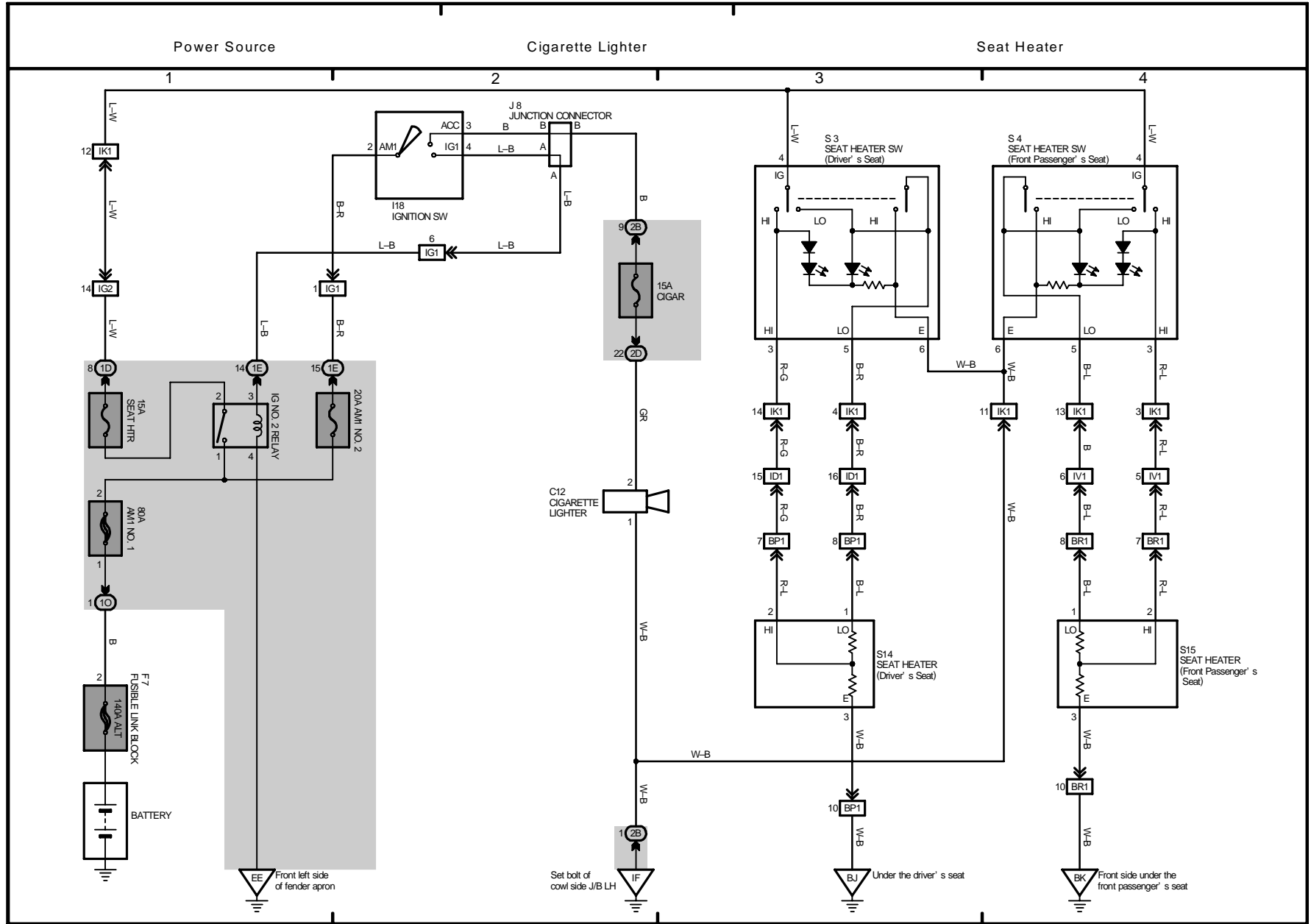







Radio and Player

\* 3 : w LEXUS Navigation System  
 \* 4 : wo LEXUS Navigation System

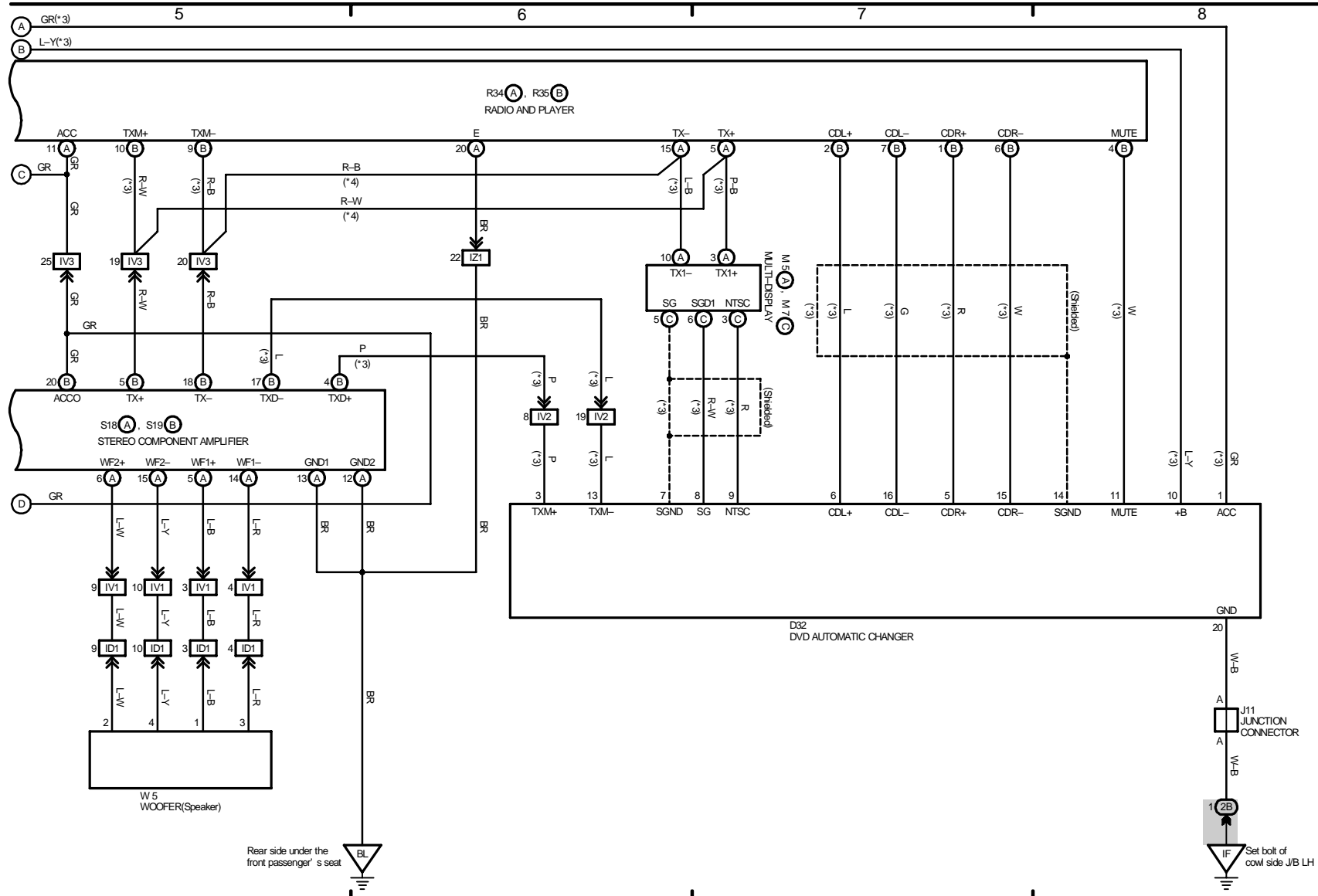

2001 LEXUS LX 470 (EMD427U)





# M OVERALL ELECTRICAL WIRING DIAGRAM

(Cont. next page)

30 LX 470

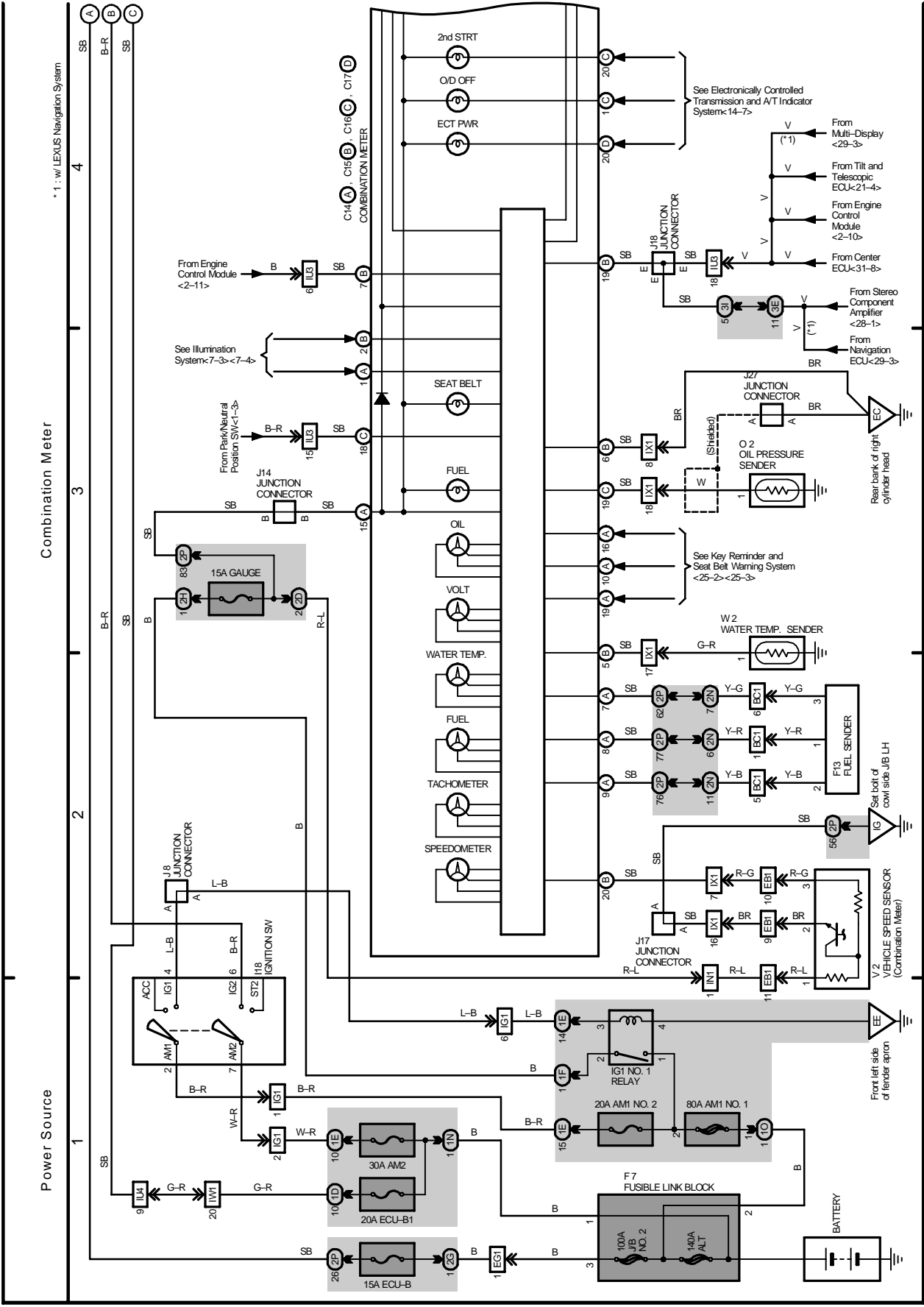







# M OVERALL ELECTRICAL WIRING DIAGRAM

31 LX 470

(Cont. next page)

## Condenser Fan and Front Air Conditioning

## Power Source

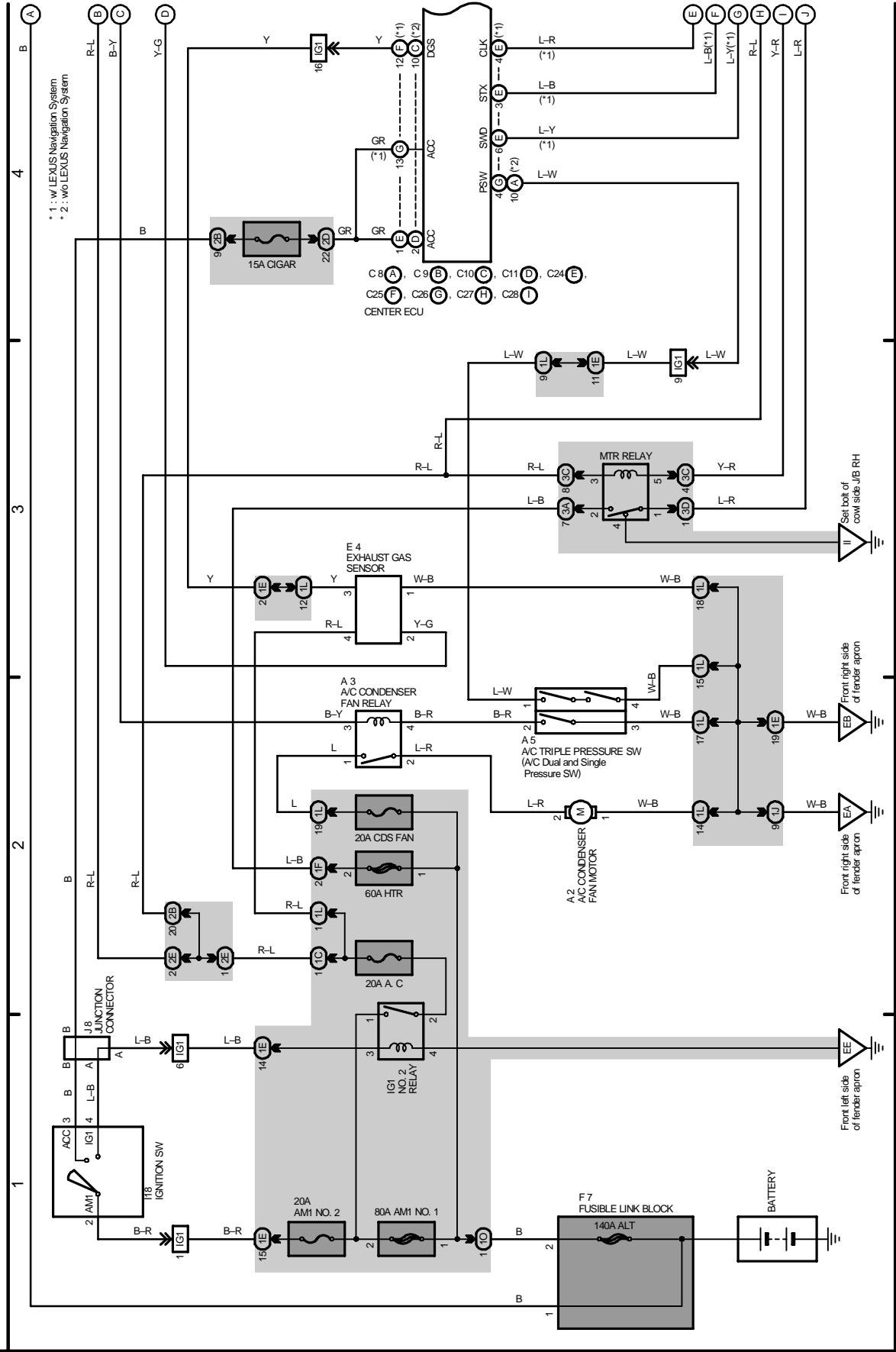

Condenser Fan and Front Air Conditioning

\* 1 : w/ LEXUS Navigation System  
 \* 2 : wo LEXUS Navigation System

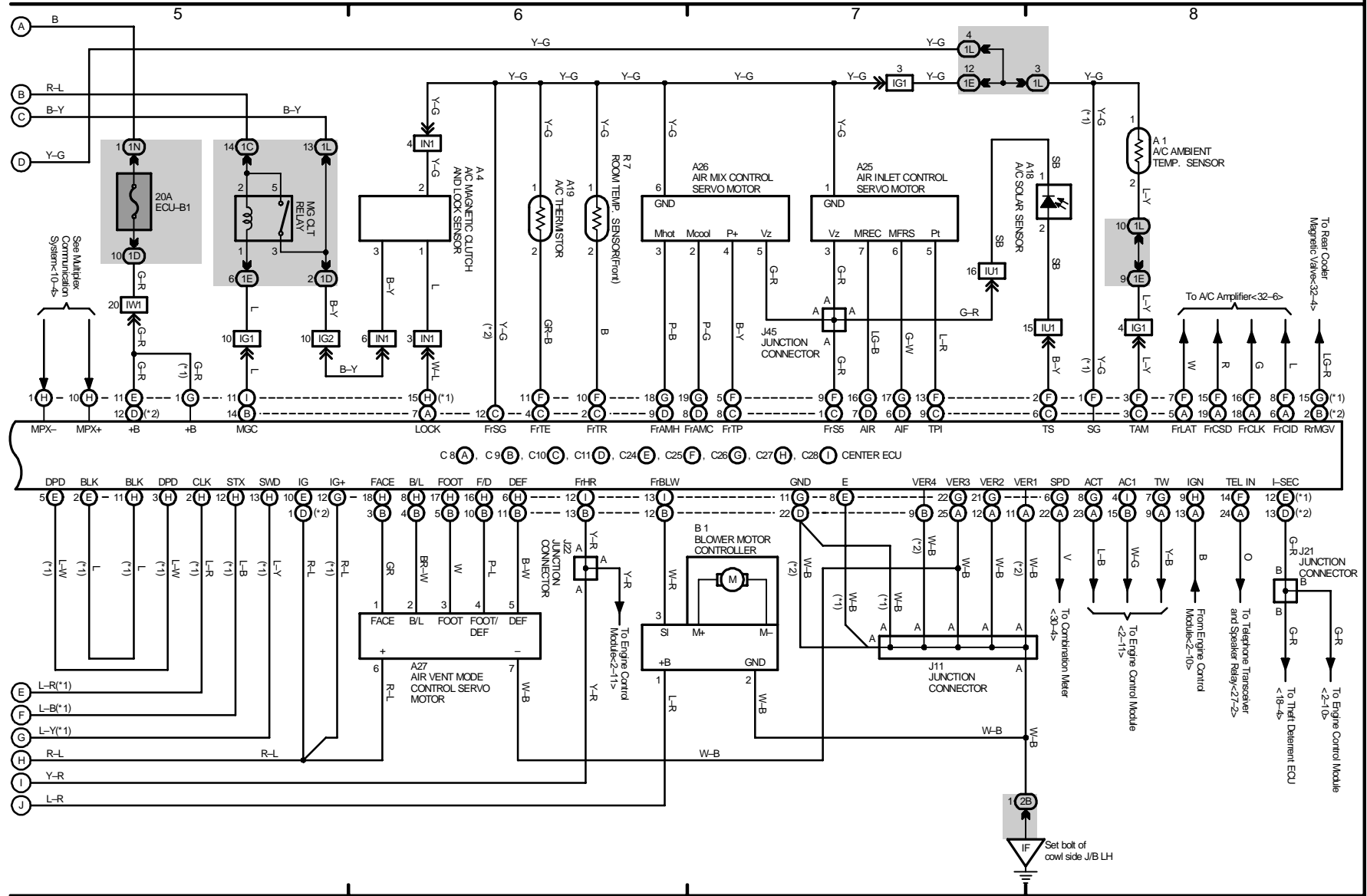

2001 LEXUS LX 470 (EWD427U)

# M OVERALL ELECTRICAL WIRING DIAGRAM

(Cont. next page)

32 LX 470

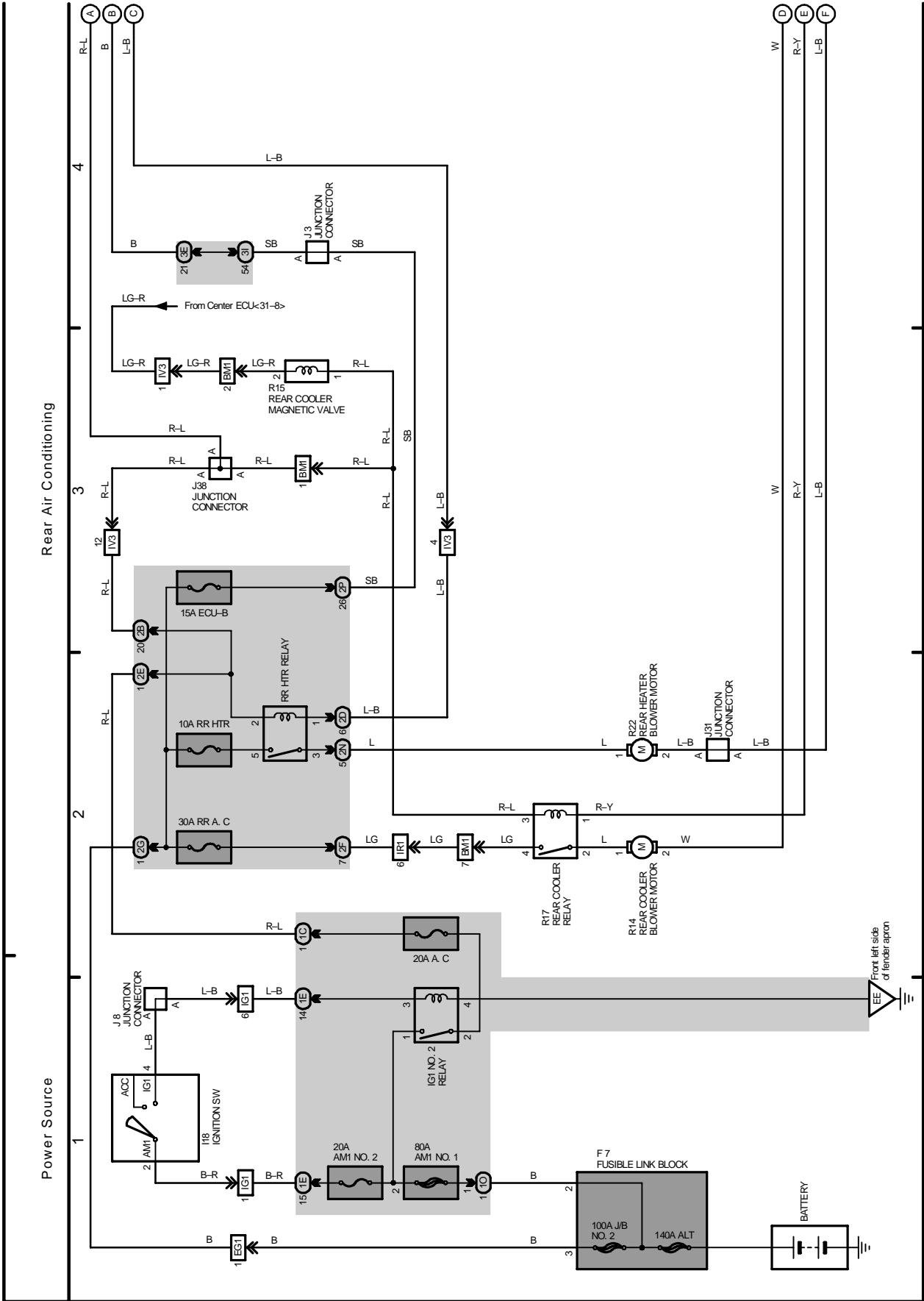

Rear Air Conditioning

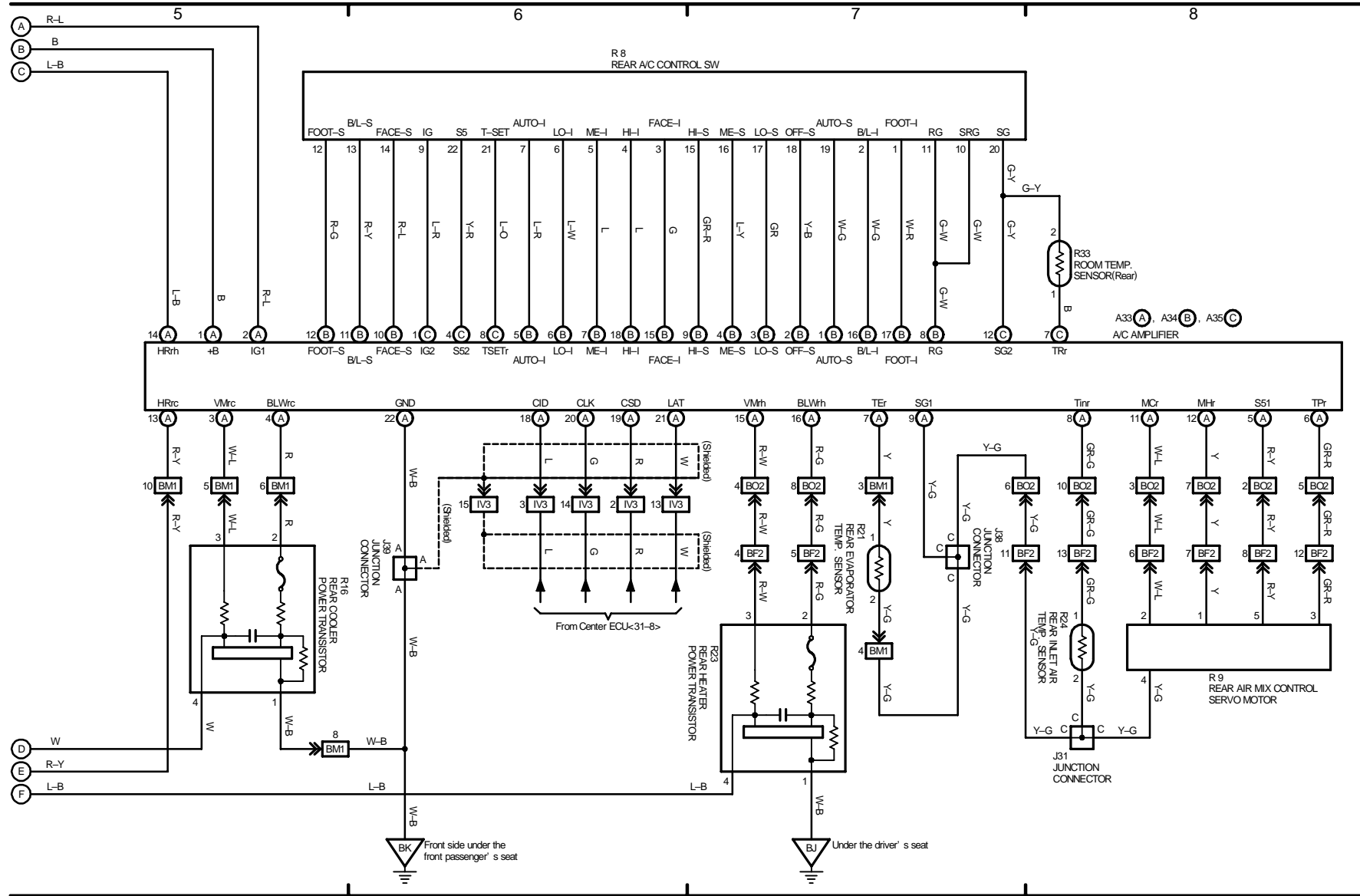

2001 LEXUS LX 470 (EWD427U)